

**CEG-12
CUSTOMER SPECIFICATION**

II

TABLE OF CONTENTS

- 1. APPLICATION
- 2. MODEL NUMBER
 - 2.1 Customer
 - 2.2 Varex Imaging CEG-12
- 3.0 INSERT
 - 3.1 Physical
 - 3.2 Anode
 - 3.3 Electrical
 - 3.4 Filament (Cathode)
 - 3.5 Input Rates
 - 3.6 Vacuum Quality
- 4.0 HOUSING ASSEMBLY
 - 4.1 Physical
 - 4.2 Outline Drawing
 - 4.3 X-ray Beam
 - 4.4 Inherent Filtration
 - 4.5 Electrical
 - 4.6 Cooling
- 5.0 TESTING
 - 5.1 Final Acceptance Test
 - 5.2 Customer Acceptance Test

**CEG-12
CUSTOMER SPECIFICATION**

TABLE OF CONTENTS

6.0 SEASONING & DAILY WARM-UP

6.1 Seasoning Procedure

7.0 SYSTEM DATA

7.1 Thermal

7.2 Modifications

7.3 Regulatory

7.4 Label

7.5 Documents

8.0 RETURN PROCEDURE

8.1 Defective Units

9.0 REVISION

Addendum A

Addendum B

**CEG-12
CUSTOMER SPECIFICATION**

III

1.0 APPLICATION

1.1 The specification applies to the X-ray Tube Model CEG-12.

2.0 MODEL NUMBER

2.1 Customer CEG-12

2.2 Varex Imaging CEG-12

2.3 CEG-12 Assembly

2.3.1 Tube Unit 35685

3.0 INSERT

3.1 Physical

3.1.1 Cathode grounded, end window, Syltherm HF cooled irradiation X-ray tube.

3.2 Anode

3.2.1 The anode is Copper with the target material attached. The anode is cooled with Syltherm HF.

3.2.2 Target Material Tungsten

3.2.3 Target surface is parallel to the Beryllium window

3.3 Electrical

3.3.1 kVP Maximum Anode-to-ground 180 kVP

**CEG-12
CUSTOMER SPECIFICATION**

- 3.4 Filament (Cathode)
 - 3.4.1 The filament is Tungsten and the leads are insulated from the grounded support and focusing structure, but must be maintained at ground potential.
 - 3.4.2 Operating Voltage Range 20-35 Volts DC
 - 3.4.3 Operating Current Range 7-10 Amperes
 - 3.4.4 Maximum Filament Current 11.5 Amperes
(in-rush current limit required)
 - 3.4.5 Insulation Resistance at 500 VDC
Filament to ground > 500 MΩ
Target to ground > 500 MΩ
Filament to target > 500 MΩ
 - 3.4.6 Filament Characteristics Refer to Figure 1
- 3.5 Input Rates
 - 3.5.1 Maximum Load 12,000 Watts
 - 3.5.2 Operating kV Range (at 12kW max) 120-180 kV
 - 3.5.3 Rating Charts Refer to Figure 2
- 3.6 Vacuum Quality
 - 3.6.1 Maximum Pressure 1.0 x 10⁻⁴ Torr
 - 3.6.2 Degradation Limit
 - 3.6.2.1 No more than one logarithmic scale in Torr

**CEG-12
CUSTOMER SPECIFICATION**

4.0 HOUSING ASSEMBLY

4.1 Physical

4.1.1 Weight 122 lbs. (55 kg)

4.2 Outline Drawing Refer to Figure 3

4.3 X-ray Beam

4.3.1 Target to Window Distance 36 mm

4.3.2 Be Window Opening 146 mm

4.4 Inherent Filtration 4.32 mm Beryllium

4.5 Electrical

4.5.1 Cable Receptacles

4.5.1.1 Anode R28

4.5.1.2 Filament 62" No. 14 AWG

4.6 Cooling

4.6.1 Anode and Cathode Cooling 19 L/min

4.6.1.1 Fittings:

PARKER Nipple - FF-502-10FO
PARKER COUPLER - FF-501-10FO

4.6.2 Cooling Medium Slytherm HF

4.6.3 Cooling Temperature at Inlet (max) 35 (deg)C

4.6.4 Pressure at Inlet (max) 6 Bar

**CEG-12
CUSTOMER SPECIFICATION**

5.0 TESTING

5.1 Final Acceptance Test

5.1.1 Stability

5.1.1.1 180kV, 66.6mA for 1 hour 0 Arcs Max

5.2 Customer Acceptance Test

5.2.1 Stability 180kV, 66.6mA for 1 hour 0 Arcs Max

5.2.2 Radiation Leakage Test

5.2.2.1 Customer is responsible for compliance with domestic and/or international cabinet X-ray regulations is the responsibility of the customer and shall be achieved at the system level.

6.0 SEASONING & DAILY WARM-UP

6.1 Seasoning Procedure Refer to Figure 4

7.0 SYSTEM DATA

7.1 Thermal

7.1.1 Maximum System Heat Generated 12,000 Watts

7.2 Environmental Limits

**CEG-12
CUSTOMER SPECIFICATION**

- 7.2.1 Operating Limits (must be non-condensing environment)
 - 7.2.1.1 Temperature 5°C to 40°C
 - 7.2.1.2 Humidity 30% to 90%
- 7.2.2 Shipping & Storage Limits (Be window Vacuum Cap is required)
 - 7.2.2.1 Temperature -10°C to +70°C
 - 7.2.2.2 Humidity 10% to 95%
- 7.3 Modifications
 - 7.3.1 It is necessary to consult with Varex Imaging for any technical modifications to the tube.
- 7.4 Regulatory
 - 7.4.1 RoHS and REACH
- 7.5 Label - Each unit will be labeled with the following:
 - 7.5.1 Serial/Model Number Refer to Figure 5
 - 7.5.2 Be Label Refer to Figure 5

**CEG-12
CUSTOMER SPECIFICATION**

7.6 Documents - Each unit will be shipped with the following documents:

7.6.1 Tube Service Report 133232

7.6.2 Customer Data Sheet Refer to Figure 6

8.0 RETURN PROCEDURE

8.1 Defective Units

8.1.1 If the unit fails to meet the requirements specified in Section 2.0 through 7.0. The unit will be returned to Varex Imaging with a completed X-ray Test Checklist.

8.1.2 Returned units shall be packed in original shipping cartons.

**CEG-12
CUSTOMER SPECIFICATION**

9.0 REVISION

A

1. Establish.

B

1. Specify operating kV range.
2. Specify cooling medium, inlet temperature and pressure.
3. Update filament characteristics chart.
4. Remove XR PURE from specification.

C

1. Update Be thickness.

**CEG-12
CUSTOMER SPECIFICATION**

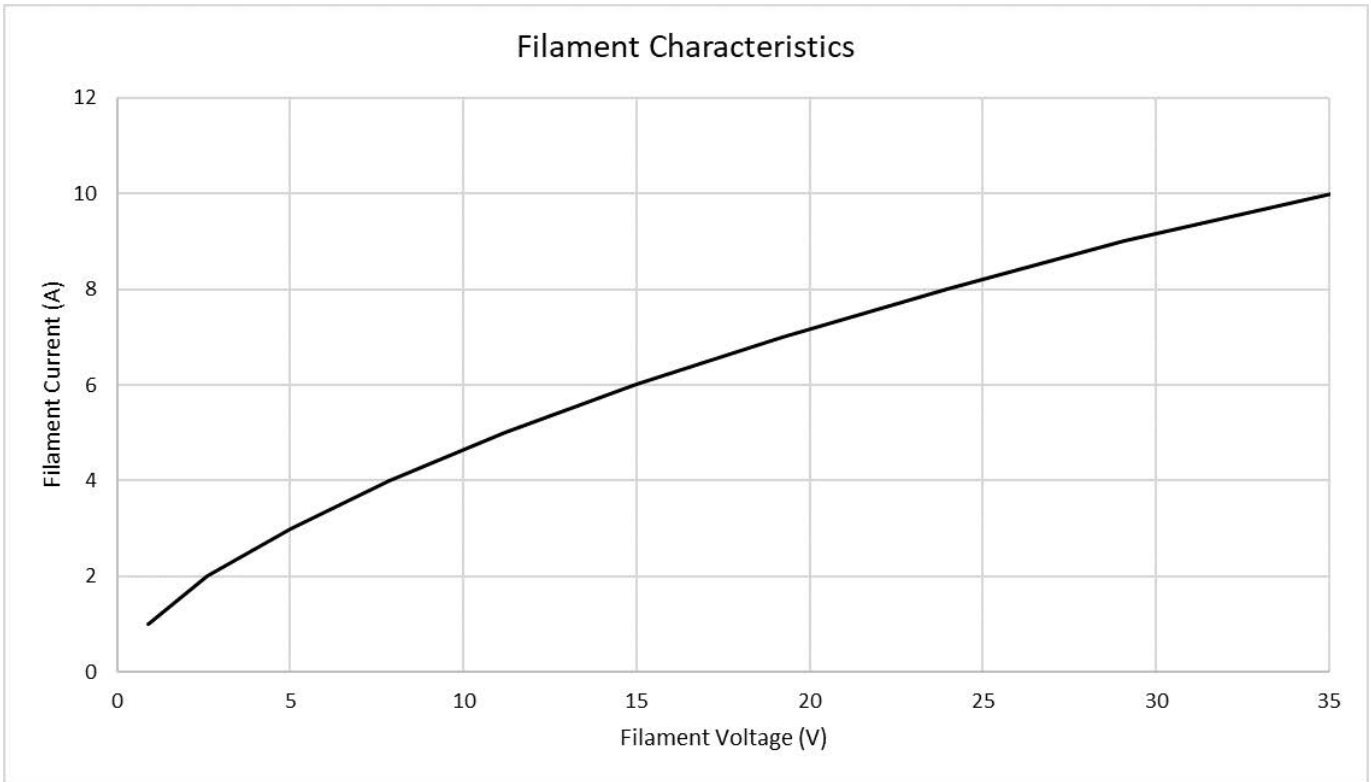

Figure 1 Filament Characteristics

**CEG-12
CUSTOMER SPECIFICATION**

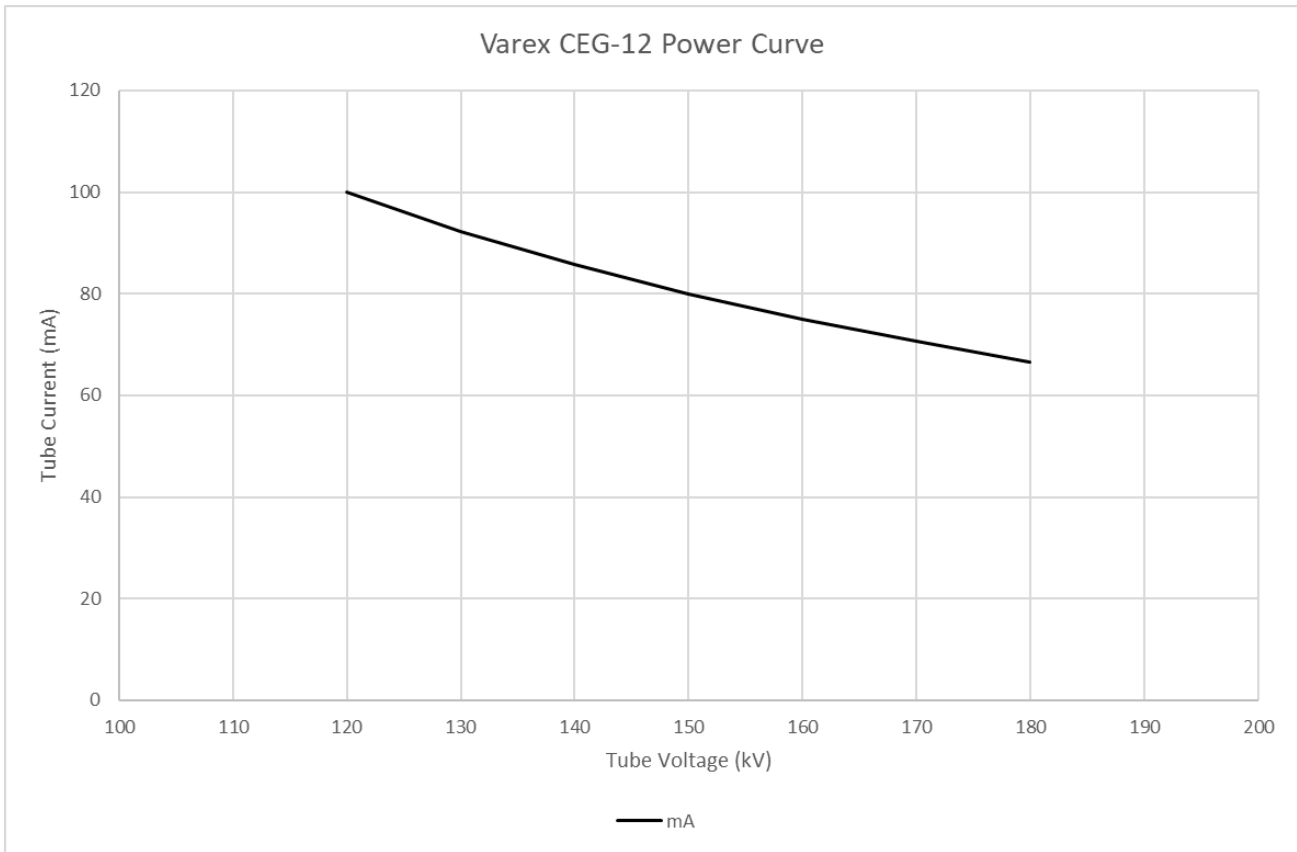

Figure 2 Rating Chart

CEG-12
CUSTOMER SPECIFICATION

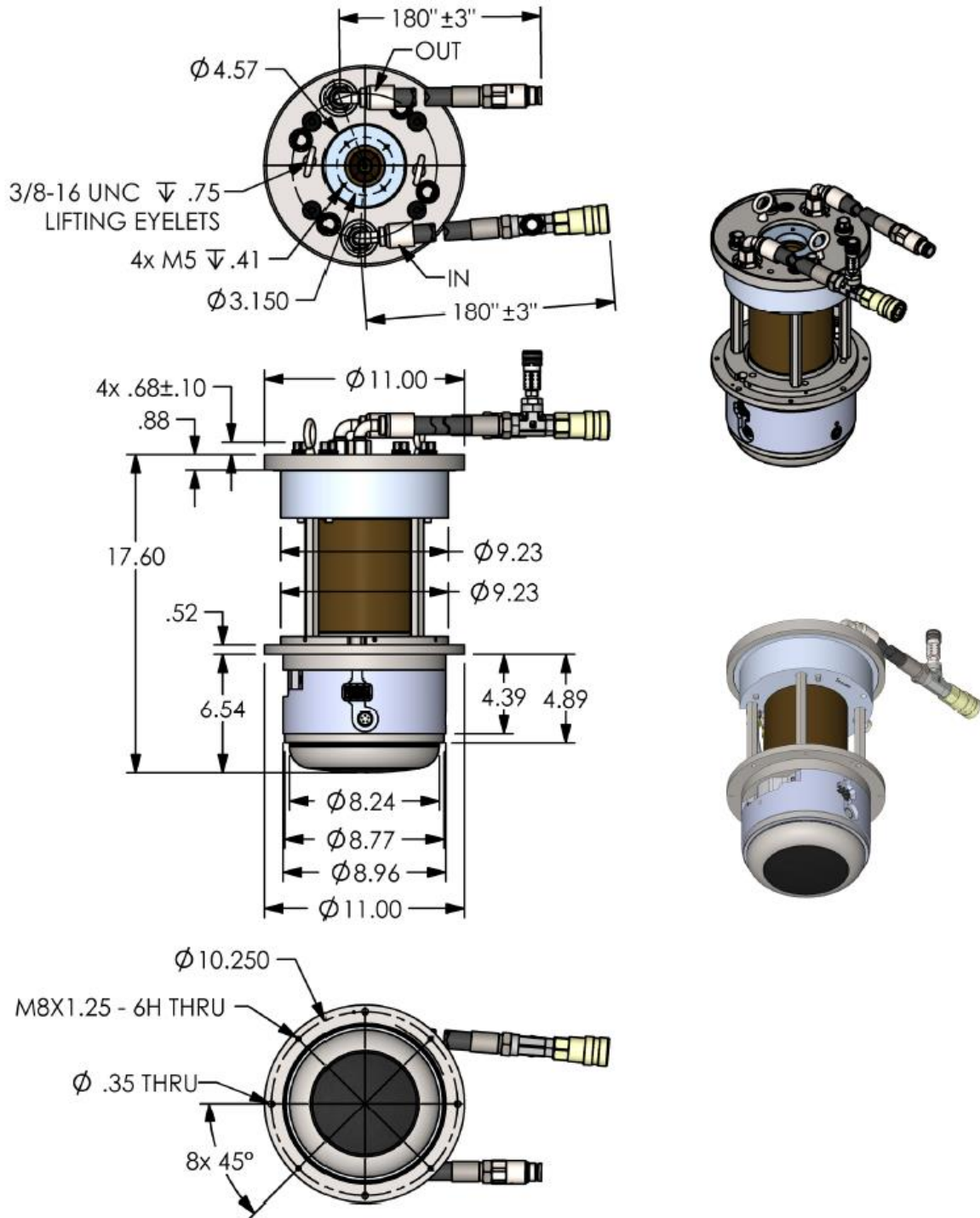

Figure 3 Outline Drawing (10013029)

**CEG-12
CUSTOMER SPECIFICATION**

Schedule for Warm-up

Warm-up should be run after 24 hours of idle time.

kV	mA	Ramp (min)	Hold (min)
75	10	0.5	2
125	40	0.5	2
170	40	0.5	2
180	40	0.5	2

Figure 4 Schedule for Aging

CEG-12
CUSTOMER SPECIFICATION

VAREX IMAGING	
TYPE	CEG-12
PART No	35685
MANUFACTURED	OCTOBER 2024
NORM. VOLTAGE	180 kV
POWER	12 kW
INH. FILTRATION	2.54 mm Be
FILAMENT A (V)	10 A
FOCAL SPOT	80mmOD 36mmID
SERIAL No	00000-1P



4122 AG

130080 A

Figure 5 Labels

CEG-12
CUSTOMER SPECIFICATION

51915-935-AC
P/N 35685

Tube Certification Report
CEG-12

Tube Type : CEG-12
Serial Number

<u>Item</u>	<u>Standard</u>	<u>Results</u>
Full Power Test	180 kV, 66 mA 60 min, 0 kicks	<input type="text"/>

Do Not Print - Not Compliant

Radiation Leakage:
Compliance with domestic and/or international cabinet X-ray regulations is the responsibility of the customer and shall be achieved at the system level.

Sign: _____

Date

Verify

Figure 6 Customer Data Sheet