



Note: Document originally drafted in the English language.
注释：文件最初用英语起草。

Product Description

The GS-5173 is a 7.5" (190.5 mm) 140 kV, 3.8 MJ (5.3 MHU) maximum anode heat content, rotating anode insert. This insert is specifically designed for United Imaging Healthcare CT Scanners. The insert features a 7° tungsten-rhenium facing on molybdenum with a graphite backed target and is available with the following nominal focal spot:

0.5 x 1.0
1.0 x 1.0
IEC 60336

Loading Factor for slit focal:
Small - 140 kV, 150 mA
Large - 140 kV, 210 mA

Maximum Anode Cooling Rate:
9,600 W (13,440 HU/sec)

Continuous Anode Input Power:
6,300 W (8,820 HU/sec)

Nominal CT Anode Input Power:
Small - 36 kW IEC 60613:2010
Large - 50.4 kW IEC 60613:2010

Nominal CT Scan Power Index:
Small - 36 kW IEC 60613:2010
Large - 49 kW IEC 60613:2010

Reference Axis:
Perpendicular to port face.

This insert is intended for use in a Varex Imaging B-320H housing.

产品说明

GS-5173 是一款具有 7.5" (190.5 mm) 靶盘, 140 kV, 3.8 MJ (5.3 MHU) 最大阳极热容量的旋转阳极 X 射线管芯。该管芯专门针对 United Imaging Healthcare CT 扫描仪而设计。该管芯的靶盘结构为 7° 靶角, 铇钨钼合金靶材, 石墨基底, 可提供下列尺寸的标称焦点:

0.5 x 1.0
1.0 x 1.0
IEC 60336

狭缝焦点的测量条件:
小焦点 - 140 kV, 150 mA
大焦点 - 140 kV, 210 mA

最大阳极冷却速率:
9,600 W (13,440 HU/sec)

连续阳极输入功率:
6,300 W (8,820 HU/sec)

标称CT阳极输入功率:
小焦点 - 36 kW IEC 60613:2010
大焦点 - 50.4 kW IEC 60613:2010

标称CT扫描功率指数
小焦点 - 36 kW IEC 60613:2010
大焦点 - 49 kW IEC 60613:2010

参考轴:
垂直于窗口面。

该管芯适用于 万睿视影像 B-320H 管套。

3Ø 105 Hz 

0.5 Focal Spot 7°
 0.5 焦点 7°

Volume scan time (seconds)	Maximum allowed tube current (mA) as a function of the following starting heat storage and tube voltages								
	Starting heat storage = 40%			Starting heat storage = 60%			Starting heat storage = 80%		
	100 kV	120kV	140kV	100 kV	120kV	140kV	100 kV	120kV	140kV
1	360	300	257	360	300	257	360	300	257
2	360	300	257	360	300	257	360	300	257
4	360	300	257	360	300	257	360	300	257
10	360	300	257	360	300	257	324	270	231
20	360	300	257	360	300	257	264 a	220 a	189 a
30	360	300	257	360	300	257	201 a	168 a	144 a
50	360	300	257	287 a	239 a	205 a	145 a	121 a	104 a

3Ø 105 Hz 

1.0 Focal Spot 7°
 1.0 焦点 7°

Volume scan time (seconds)	Maximum allowed tube current (mA) as a function of the following starting heat storage and tube voltages								
	Starting heat storage = 40%			Starting heat storage = 60%			Starting heat storage = 80%		
	100 kV	120kV	140kV	100 kV	120kV	140kV	100 kV	120kV	140kV
1	504	420	360	504	420	360	390	325	279
2	504	420	360	504	420	360	380	317	271
4	504	420	360	504	420	360	362	302	259
10	504	420	360	500	417	357	324 a	270 a	231 a
20	504	420	360	419	350	300	264 a	220 a	189 a
30	481	401	344	361	301	258	201 a	168 a	144 a
50	378	315	270	287a	239 a	205 a	145 a	121 a	104 a

Note:
 1. Limits are based on maximum track rating except for the following codes:
 a - Limited by available heat storage.
 b - Limited by window heating.
 c - Limited by filament emission.
 2. H.S. = Heat Storage
 kV = Tube Voltage

注释
 1. 除如下所列规则外，限制均以最大轨道额定值为依据：
 a - 受有效热容量限制。
 b - 受窗口加热限制。
 c - 受灯丝放射限制。
 2. H.S. = 热容量
 kV = 管电压

Note:
 Rating charts reflect maximum tube performance. Tube operation is ultimately limited by system software.

注释
 额定值表反映最大管性能。管的工作状况最终受系统软件的限制。

3 Ø

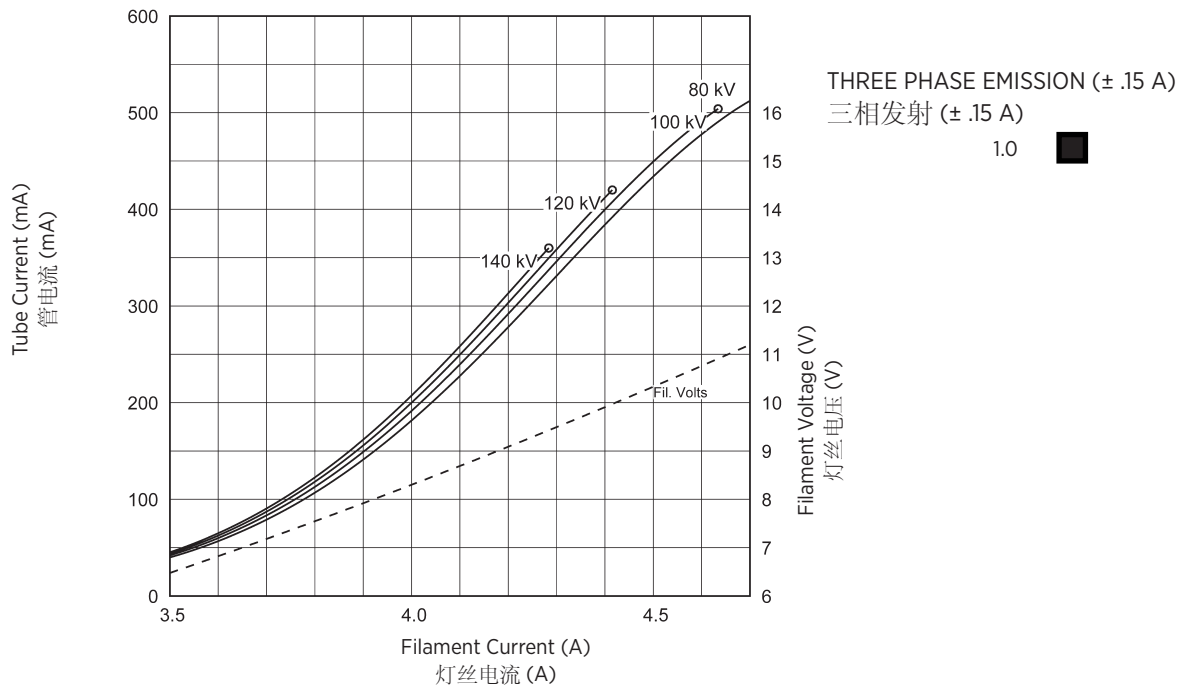
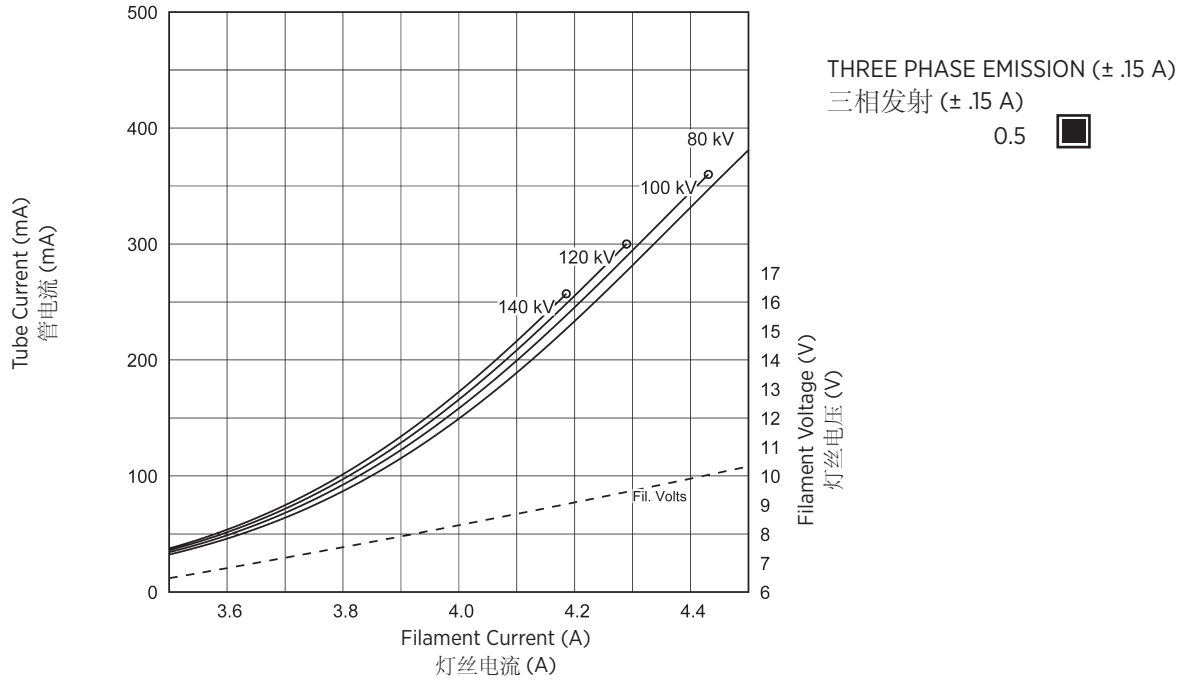

Product Description	
Maximum Peak Voltage	140 kV
Anode to Ground	70 kV
Cathode to Ground	70 kV
Maximum X-ray Tube Assembly Heat Content	3.8 MJ (5.3 MHU)
Nominal Continuous Input Power (Includes stator heat)	6.4 kW (9.0 kHU/sec) IEC 60613:2010
Maximum Housing Temperature	80°C
Maximum Heat Exchanger Dissipation	6.4 kW (9.0 kHU/sec)
Focal Point Position (Central Ray) Within 1mm (X, Y Direction from the center of radiation port.)	
X-Ray Tube Assembly	
Permanent Filtration	0.5 mm Al @ 75 kV IEC 60522/1999
Additional Filtration	1.5 mm Al @ 75 kV IEC 60522/1999
Minimum Total Filtration	2.0 mm Al @ 75 kV IEC 60522/1999
Loading Factors for Leakage Radiation	140 kV, 43 mA
High Voltage Cable Receptacles	Per IEC 60526
Ambient Air Temperature Limits for Operation	5°C to 40°C
Temperature Limits for Storage and Transport	-20°C to +75°C
Humidity	+10% to +90%
Atmospheric Pressure Range	70 kPa to 106 kPa
Weight - Housing & Heat Exchanger	213 lbs. ±2.0 lbs.
IEC Classification	Class 1
Safety Devices - Thermal Switches	
External - Normally Closed Contact	Opening at 80°C ±3.9°C
Internal - Normally Closed Contact	Opening at 110°C ±4.4°C
Pressure Switch	
Normally Open contact	closes at 3.0 PSID ±1.0 PSID
Filament Frequency Limits	50 HZ - 40 KHZ
Power Supply	DC

产品说明	
最大峰值电压	140 kV
阳极到地	70 kV
阴极到地	70 kV
最大 X 射线管组件热含量	3.8 MJ (5.3 MHU)
标称连续输入功率 (包括定子热量)	6.4 kW (9.0 kHU/sec) IEC 60613:2010
最大管套温度	80°C
交换器最大热耗散	6.4 kW (9.0 kHU/seg)
焦点位置 (中心射线) 在 1 mm 内 (源于辐射端口中心的 X、Y 方向)	
X 射线管组件	
固有滤过	0.5 mm Al @ 75 kV IEC 60522/1999
附加滤过	1.5 mm Al @ 75 kV IEC 60522/1999
最小总滤过	2.0 mm Al @ 75 kV IEC 60522/1999
泄漏辐射加载系数	140 kV, 43 mA
高压电缆插座	IEC 60526
环境气温工作限值	5°C a 40°C
存储与运输温度限值	-20°C ~ +75°C
湿度	+10% ~ +90%
大气压范围	70 kPa ~ 106 kPa
重量: 管套和热交换器	213 lbs. ±2.0 lbs.
IEC 分级	1 类
重量: 管套	
外部 - 常闭接点	开启温度 80°C ±3.9°
内部 - 常闭接点	开启温度 110°C ±4.4°C
压力开关 - 常开触点	在 3.0 PSID ±1.0 PSID 时闭合
灯丝频率限值	50 HZ - 25 KHZ
电源	直流

Dimensions are in millimeters
尺寸单位为毫米

Dimensions are for reference only
维度是供仅参考

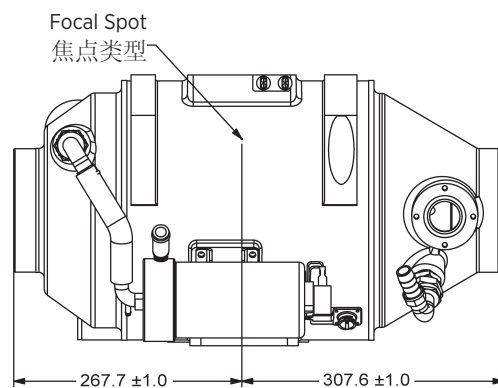
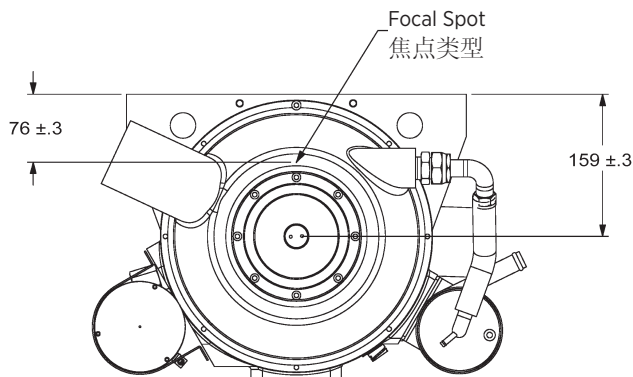
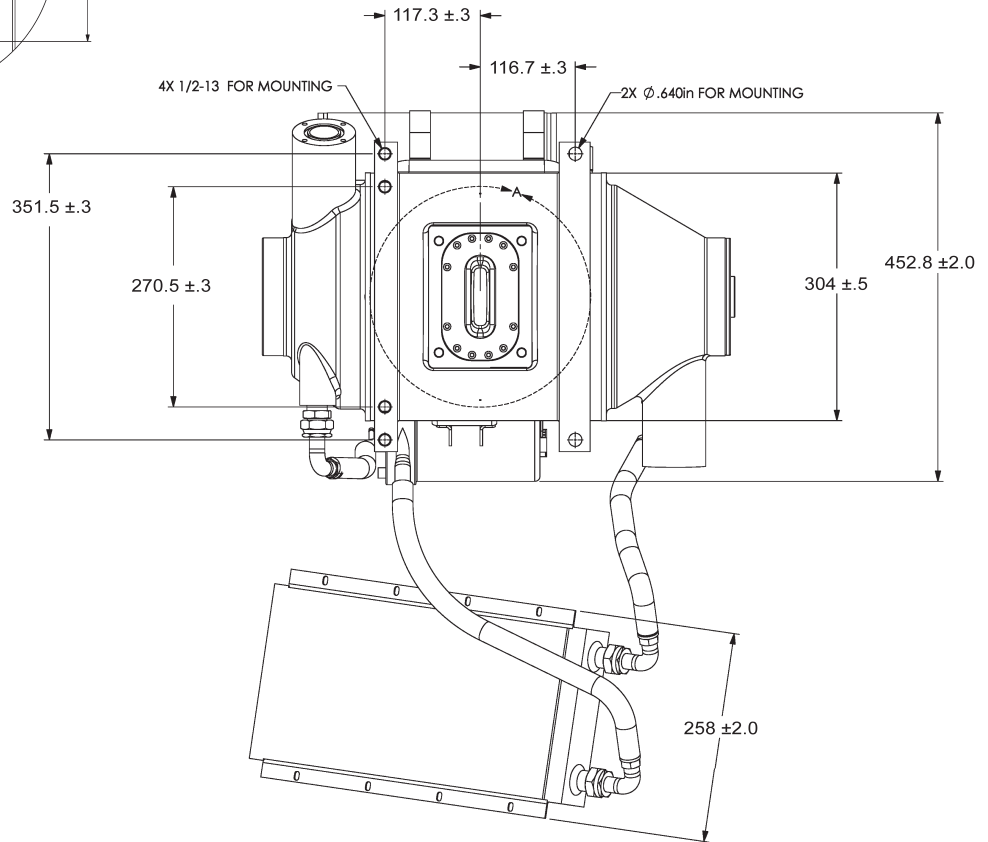
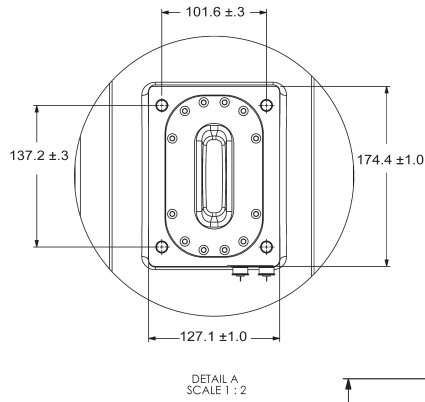

X-Ray Tube Housing Assembly Heating and Cooling
X射线管组件加热/冷却曲线

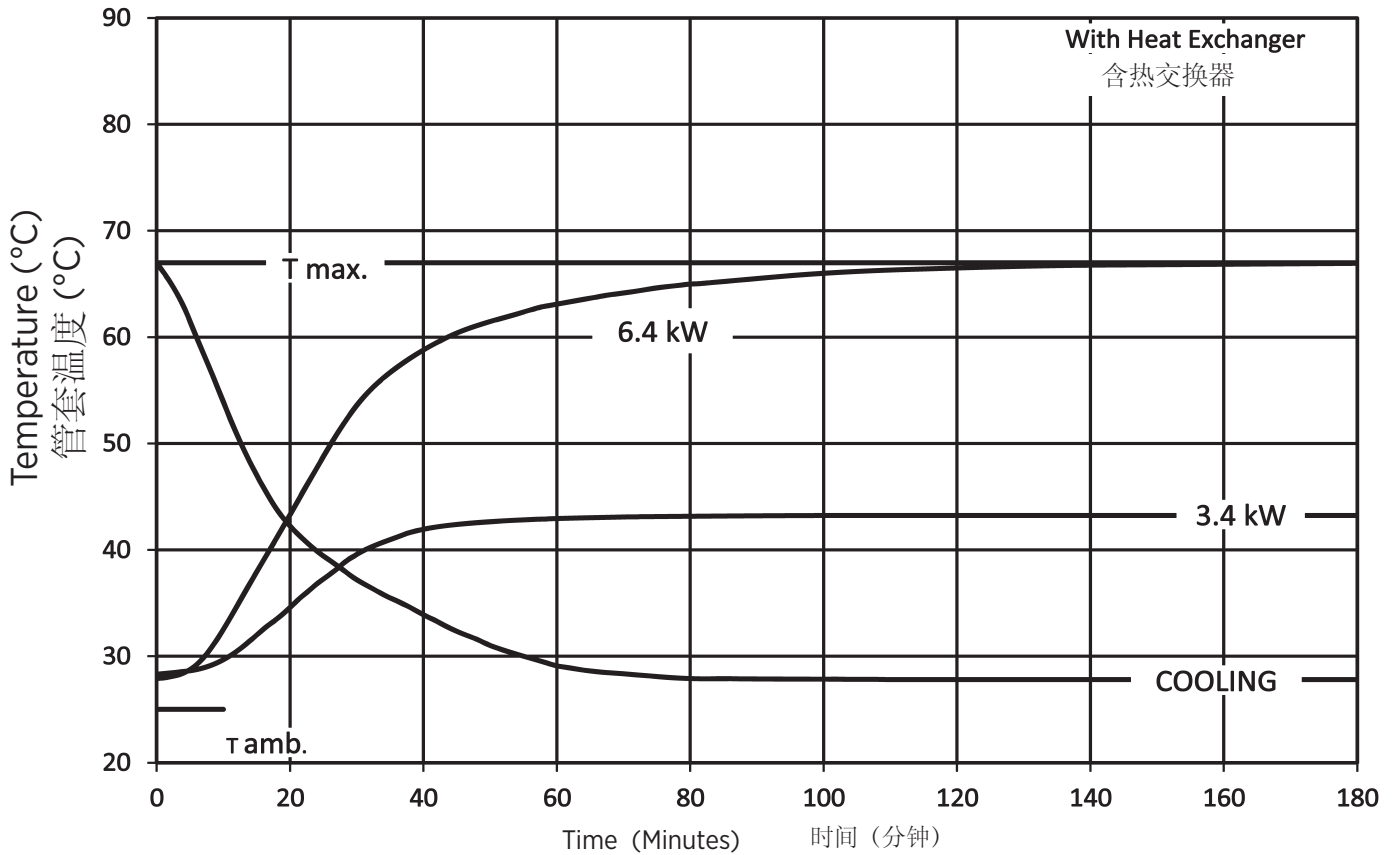

Note:

- Heat inputs into housing include tube power, filament power, and stator power.
- Heating curves based on no restrictions of natural convection around tube housing assembly.
- Heating and cooling curves reflect maximum tube performance. Tube operation is ultimately limited by system software control.

注释:

- 向管套的热量输入包括管功率、灯丝功率和定子功率。
- 加热曲线以管套组件周围无自然对流的限制为根据。
- 加热与冷却曲线反映了管的最高性能。管的工作状况最终受系统软件控制的限制。

Wiring Diagram

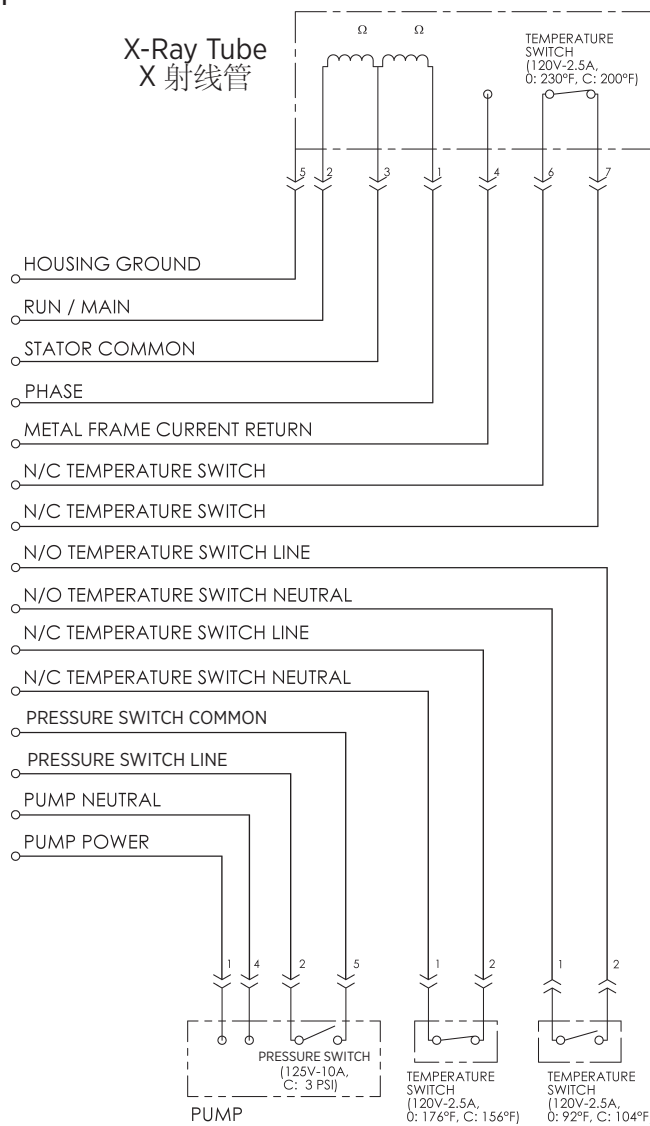

Stator Drive Frequency 定子驱动频率	RPM
105 Hz	5700 - 6300

Stator Type:	
Stator Coil Resistance:	
Black to White	8.3 Ω ±15%
Green to White	8.3 Ω ±15%
Starter Voltage:	
105 Hz	Start 480 VAC Run 160 VAC
Starter Current:	
105 Hz	Start 9 Amps Run 3 Amps
Time to Full Speed:	
105 Hz	0 - 6300 RPM 20 Sec.
X-Ray Tube Assembly:	
GS-5173/B-320H	IEC 60601-2-28
Note: Anode brake is allowed after 2 minutes if no further exposure is needed.	

定子的类型:	
定子线圈电阻:	
黑色到白色	8.3 Ω ±15%
绿色到白色	8.3 Ω ±15%
启动器电压:	
105 Hz	启动 480 VAC 运行 160 VAC
启动电流:	
105 Hz	启动 9 安培 运行 3 安培
达到全速的时间:	
105 Hz	0 - 6300 RPM 20 Sec.
X 射线管组件:	
GS-5173/B-320H	IEC 60601-2-28
注: 如果无需继续曝光, 2分钟后可以止动阳极靶。	

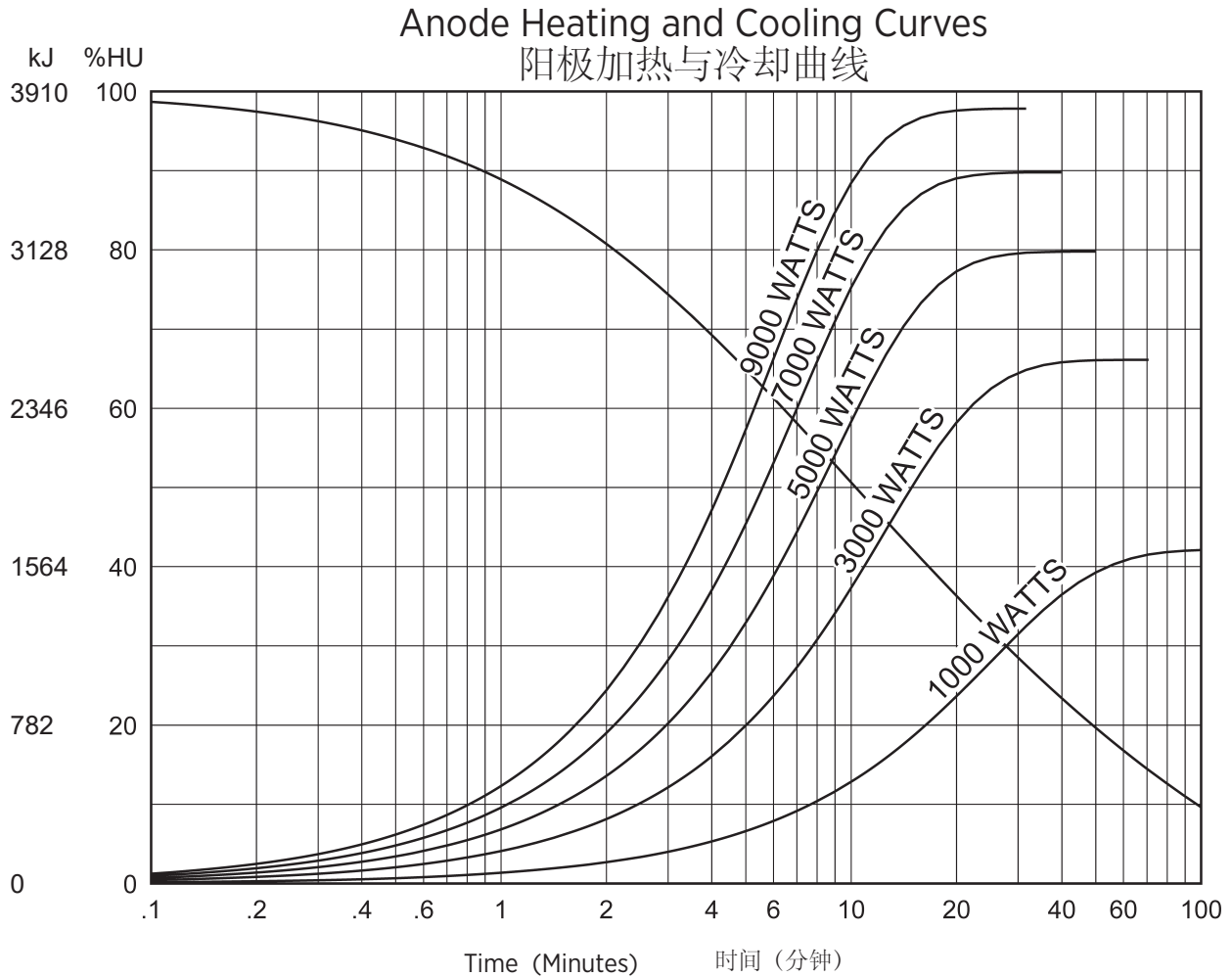

Note:
Heating and cooling curves reflect maximum tube performance. Tube operation is ultimately limited by system software control.

注释:
加热与冷却曲线反映了管的最高性能。管的工作状况最终受系统软件控制的限制。

Manufactured by Varex Imaging Corporation
由万睿视影像有限公司生产