

Linatron[®]Mi6SSM[™]

Modular High-energy X-Ray Source



Making the Invisible Visible



X-Ray Head Monobloc

The Linatron[®] Mi6SSM[™] is a monobloc high-energy x-ray source with pulse-to-pulse dose and energy switching capability including High, Low, Dynamic and Occupied Vehicle Scan modes. By allowing our customer to select their own combinations of dose and energy, systems incorporating the Mi6SSM x-ray source can be designed to discriminate between materials based on their density characteristics as well as increase through-put of Cargo Scans by utilizing Occupied Vehicle Scan settings. System controls are delegated to a distributed on-board system and may be controlled using a PC.

1.0 Standard Equipment and Services

1.1 X-ray Head Monobloc

The Mi6SSM Monobloc X-ray head houses all components required to generate X-rays.

1.2 Temperature Control Unit (TCU)

The TCU is used to keep the system components at a nominal 30°C (86°F).

1.3 Spare Parts Kits

- Compulsory
- Standard
- Extended

1.4 Interconnecting cables and hoses included.

Cables: 100 meters (330 ft.) max.
Hoses: 91 meters (300 ft) max. (indoor)
45 meters (150 ft) (outdoor)

1.5 Manuals

Operator Manuals are included in English.

1.6 Installation Supervision and Start-up Assistance

1.7 VAREX's Standard Warranty

2.0 X-ray Beam Characteristics

2.1. Dose Rate - measured 1 meter from target in central axis of a 10-cm x 10-cm field. Listed in Gy/min-meter. (See Table 1)

2.2. Energy - measured with Half Value Layer (HVL) method in steel and listed in inches of steel as well as nominal energy in MV. (See Table 1)

2.3. Focal Spot Size - measured using Full Width Half Max method and does not exceed 2.0 mm.

2.4. Field Flatness - measured at 1 meter from target at $\pm 7.5^\circ$ off the central axis. Listed as percent of the central axis dose rate. (See Table 1)

2.5. Field Size - field collimation is custom for each system. See Table 4 for options.

Linatron Mi6SSM

Modular High-energy X-Ray Source



2.6. Field Symmetry - beam asymmetry is measured at 1 meter from target and does not exceed 5% (for symmetric collimation options).

Table 1 - X-Ray Beam Characteristics				
Model	Nominal Energy (MV)	Half Value Layer (Inches of Steel)	Flatness (% @ ± 7.5°)	Max. Dose Rate (Rad/Min @1m)*/**
Mi6SSM Low Dose	>2.0	>.79"	≥78.0	0.05 - 0.15
	4.0	1.00"	≥69.0	1.0 - 30.0
	6.0	1.10"	≥62.0	1.0 - 100.0
Mi6SSM Standard Dose	>2.0	>.79"	≥78.0	0.05 - 0.15
	4.0	1.00"	≥69.0	40.0 - 120.0
	6.0	1.10"	≥62.0	120.0 - 300.0

*Dose rate will be affected by customer collimation and flattening filter, if applicable.
 **Dose rates are at a pulse rate of 100 PPS and are scalable to limits shown in table 2.

2.7 Energy Switching Rate

Energy can be switched pulse to pulse when controlled through the control console. Pulse sequencing can be defined for different combinations through customer interface (see Table 2).

Table 2 - Pulse Repetition Rate	
Mode	Pulse Range (pps)
Low	25 - 400
High	25 - 350
Dynamic	25 - 400*
Occupied Vehicle Scan	25 - 400

* Setting dependent

2.8. Leakage Radiation - measured along the horizontal plane at 1 meter from the beam centerline at angles > 60° outside of the primary beam. Listed as a fraction of the primary beam central axis dose rate; (excluding primary beam scatter).

Table 3 - Leakage Radiation Shielding			
Model	Energy	Leakage (Fraction)	X-Ray Head Weight (lbs.)
Mi6SSM	6MV	1.0 x 10 ⁻⁵	4800

3.0 Customer Facility Requirements

3.1 Electrical Requirements

The Linatron Mi6SSM operates from a single 15 kVA power source.

400 VAC ±10%, 3-phase, Wye, (5 wire), 50 or 60 Hz

3.1.1 Temperature Control Unit (TCU)

The TCU is connected to a separate 7kVA power source. Models are available that can operate on a line voltage of 220 VAC and 400 VAC, at 50Hz; or 220 VAC and 480 VAC, at 60Hz. If the in-line heater package is required, power requirement is increased to 20kVA.

3.2 Operating Environment

3.2.1 X-ray Head Monobloc

Temperature range for X-ray head monobloc is -30/50°C (-22/122°F), with 90% maximum relative humidity (non-condensing).

Enclosure is IP65 rated

3.2.2 Temperature Control Unit (TCU)

TCU temperature range is -40/+55°C (-40/131°F), with condensing humidity.

4.0 Optional Equipment

4.1 Custom Beam Collimation

Nonstandard field sizes are available per customer's requirement.

4.1.1 Internal Collimator Options

Table 4 - Field Collimator Options			
Slit	Min	±2°	Note Vertical Angles may be asymmetrical
	Max	+35°/-32°	
	Width	2.5mm-6mm	

*Ultra-Low Leakage Package limits collimator angles to those shown in parenthesis

Linatron Mi6SSM

Modular High-energy X-Ray Source



4.2 Remote Customer Interface

The customer system may control the Linatron via 24 V discrete I/O, serial communications, and external trigger. The dose and energy of each pulse is selected by the customer system sending a message to the Linatron before each trigger. The Linatron sends the reference dose reading for each pulse to the customer system.

4.3 PC-Based HMI

The Linatron may be configured and operated from a PC using the provided HMI software. Passwords limit access and features based on the user level. The HMI is not required when the remote customer interface is used.

Quality

Varex Imaging Corporation, Las Vegas is an ISO 9001 registered facility.



Regulatory Compliance - CE Marking

All M-Series Linatron models have been tested and meet all Varex Imaging Quality specifications and are in conformity with following standards for safety and EMC requirements.

Safety

IEC / EN 61010-1 Safety requirements for electrical equipment for measurement, control, and laboratory use
ANSI / UL / CSA C22.2 No. 61010-1
IEC 60529, Rated IP65, Dust & Water Intrusion Protection

Electromagnetic Compatibility (EMC)

FCC CFR Title 47 Part 18 Rules Conducted & Radiated Emissions

CISPR 11 / EN 55011
Conducted & Radiated Emissions

European Union Directives

2014/35/EU Low Voltage Directive
2014/30/EU EMC Directive
2011/65/EU Reduction of Hazardous Substances (RoHS)

Linatron Mi6SSM

Modular High-energy X-Ray Source

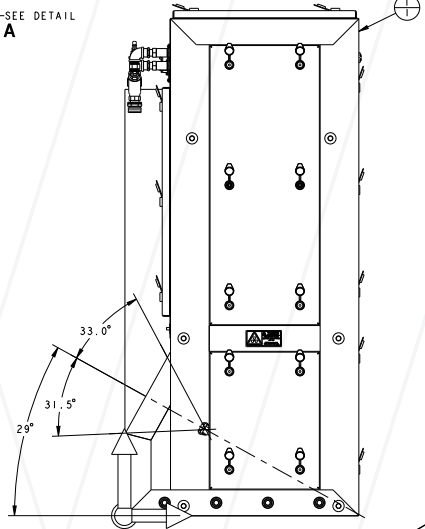
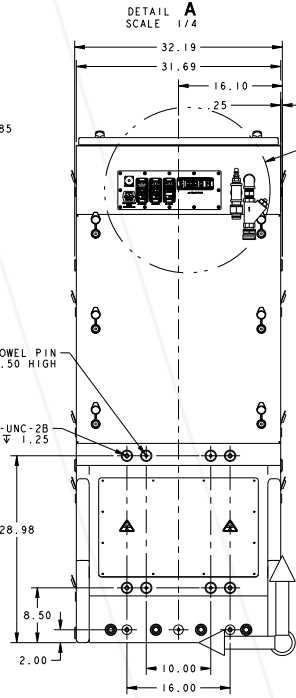
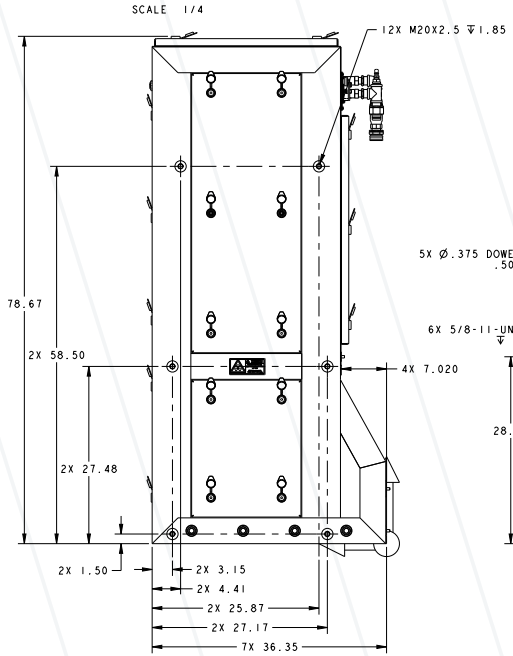
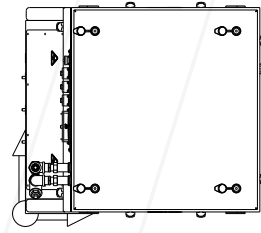
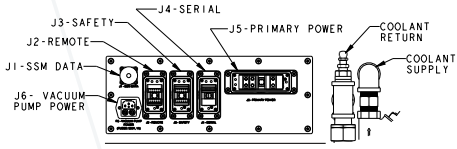
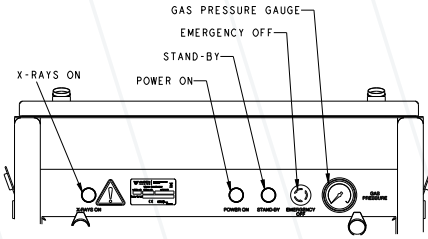

NOTES: UNLESS OTHERWISE SPECIFIED

1. SYSTEM PARAMETERS:

PARAMETER	X	Y	Z
APPROXIMATE CENTER OF GRAVITY	14.6	16.1	22.4
FOCAL POINT	12.5	16.1	13.4

2. ESTIMATED TOTAL WEIGHT 4800lbs.

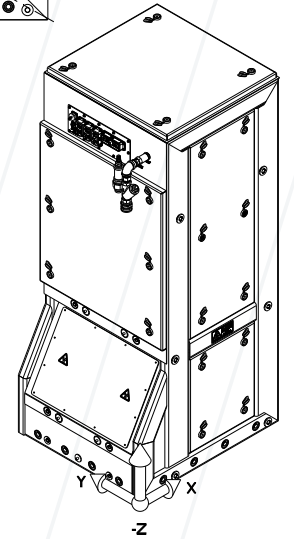

Varex Imaging and Linatron are registered trademarks, and Linatron Mi6SSM is a trademark of Varex Imaging Corporation. All other trademarks are the property of their respective owners.

Varex Imaging Corporation

USA
 HEADQUARTERS
 Salt Lake City, UT
 P: +1-801-972-5000



Las Vegas, NV
 Tel: 1-800-432-4422
 Email: industrial.support@vareximaging.com
 Website: <https://www.vareximaging.com/solutions/security-industrial-solutions>

©2023 Varex Imaging Corporation. All Rights reserved. Production of any of the material contained herein in any format or media without the express written permission of Varex Imaging Corporation is prohibited.