

VF-80 / uXHP (80KV, 100W)

X-RAY TUBE AND GENERATOR SUBSYSTEM



80kV Analytical X-ray Tube
Paired with 100W Generator
for Simplified Integration

OVERVIEW

Varex Imaging's VF-80 is an 80kV X-ray tube designed specifically for use in XRF applications. The end-window tube design allows for sample placement close to the X-ray source for efficient dose delivery. Long product lifetime is provided by the air-cooled ceramic tube design.

The Spellman uXHP is an ultra-compact X-ray generator module utilizing high voltage packaging and surface mount fabrication techniques coupled with proprietary encapsulation technology. The uXHP uses closed loop filament control circuitry providing highly regulated beam current. The low noise dc filament supply provides tight regulation, high stability and low ripple.

The combination of these market-leading components creates a sub-system optimized to the users' needs that is verified and tested as a sub-system ensuring maximum reliability out-of-the box.

FEATURES AND BENEFITS

- 80kV at 1.25mA (100W max.)
- Various target materials available
- End-window tube for efficient dose delivery
- Integrated HV cable for compact tube
- Integrated tube flange for use in vacuum system
- Over-voltage and short circuit protection
- Voltage & Current Programming
- Local & Remote Emission Control
- Safety Interlock
- RS-232, Ethernet & USB all as standard

APPLICATIONS¹

- X-ray Fluorescence Analysis
- Recycling

¹ System manufacturers are responsible for qualifying and validating their products for their intended uses and meeting all applicable regulatory requirements.

SUB-SYSTEM

Maximum Power	100W (@ 40°C maximum inlet air)
Anode Potential	20 - 80 kVp (see emission chart for details)
Maximum Tube Current	4.0 mA
Operating Temperature	+5°C to +40°C
Storage Temperature	-20°C to +70°C
Humidity	10% to 90%, non-condensing
Temperature Coefficient	0.01% per °C, voltage and current
Stability	0.05% per 8 hours after 1/2 hour warm-up

VF-80 X-RAY TUBE

Envelope	Ceramic
Target Materials	Rhodium (Rh), Tungsten (W), Palladium (Pd) Additional materials on request
Be Window Thickness	75 µm
Anode	Copper body with the target material attached
Target Angle	90° from the Central Ray
Focal Spot, typical	1.0mm
Filament Characteristics	3.3 Amps and 2.8 Volts maximum
Cooling	Forced air convection
Weight	2.3kg
Cable Length	1m
Fan	24V DC
Thermal Switch	Opens at 55°C

uXHP GENERATOR

Input Power	+24Vdc ±1V, 7.75A maximum
Voltage Control - Local	Internal multi-turn potentiometer to set voltage from 0 to full output voltage
Voltage Control - Remote	0 to +10V DC proportional from 0 to full output voltage Accuracy: ±1%; ZIN: 10Mohm
Emission Control - Local	Local: Internal potentiometer to set beam current between 0 and full output current
Emission Control - Remote	0 to +10Vdc proportional from 0 to full output current
Emission Control - Accuracy	±1%. ZIN: 10Mohm. Filament limit and filament preheat control capability is also provided
Digital Interfaces	RS-232, USB, Ethernet
Dimensions	177.8 x 78.0 x 266.7 mm ³
Weight	4.5kg
Regulatory Approvals	Compliant to EEC EMC Directive. Compliant to EEC Low Voltage Directive. RoHS Compliant. UL/CUL recognized, File E227588

DC EMISSION CHART

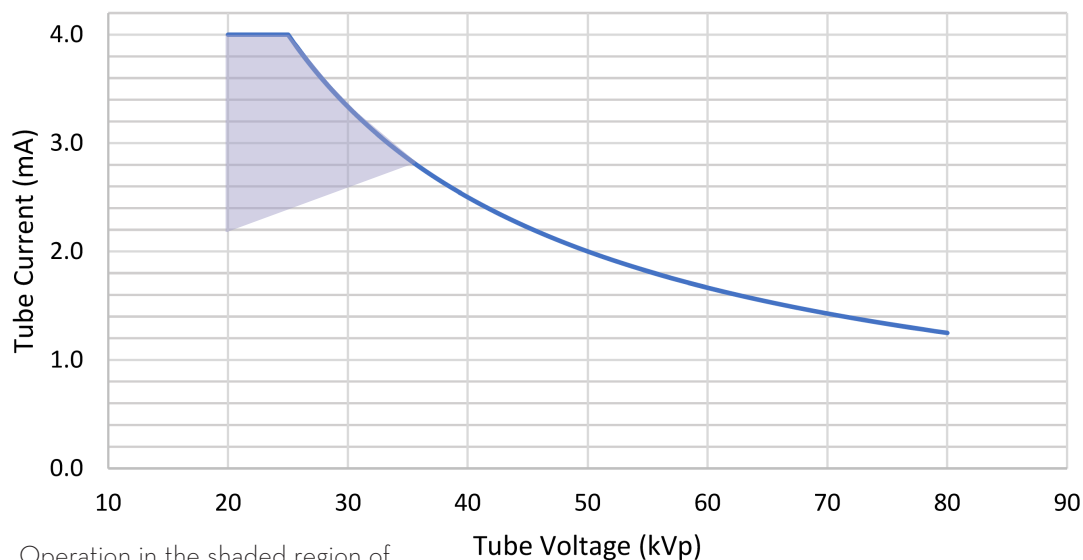

Operation in the shaded region of the emission curve requires increased filament current and may reduce the lifetime of the X-ray tube

VF-80JM

Dimensions are for reference only

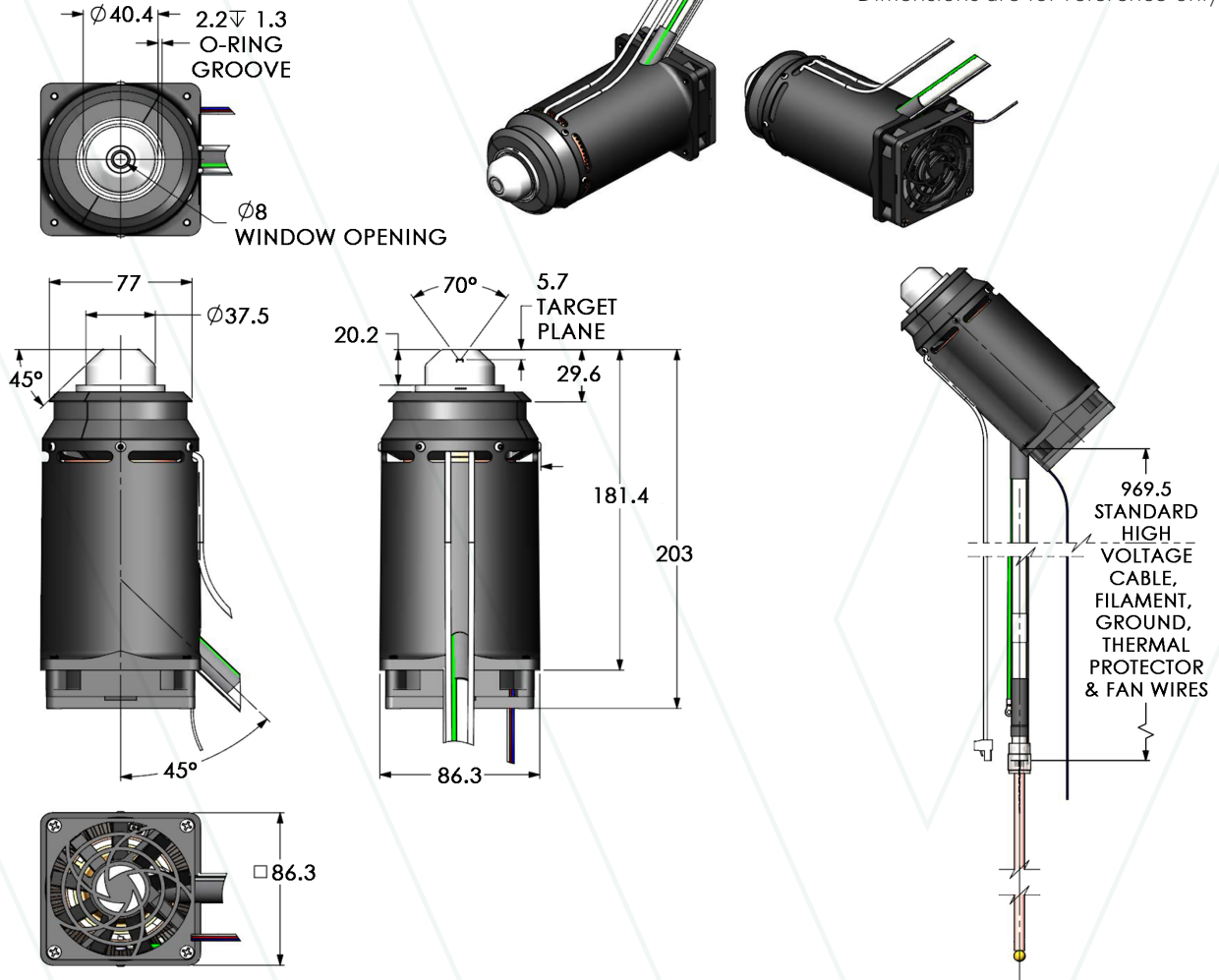

uXHP GENERATOR

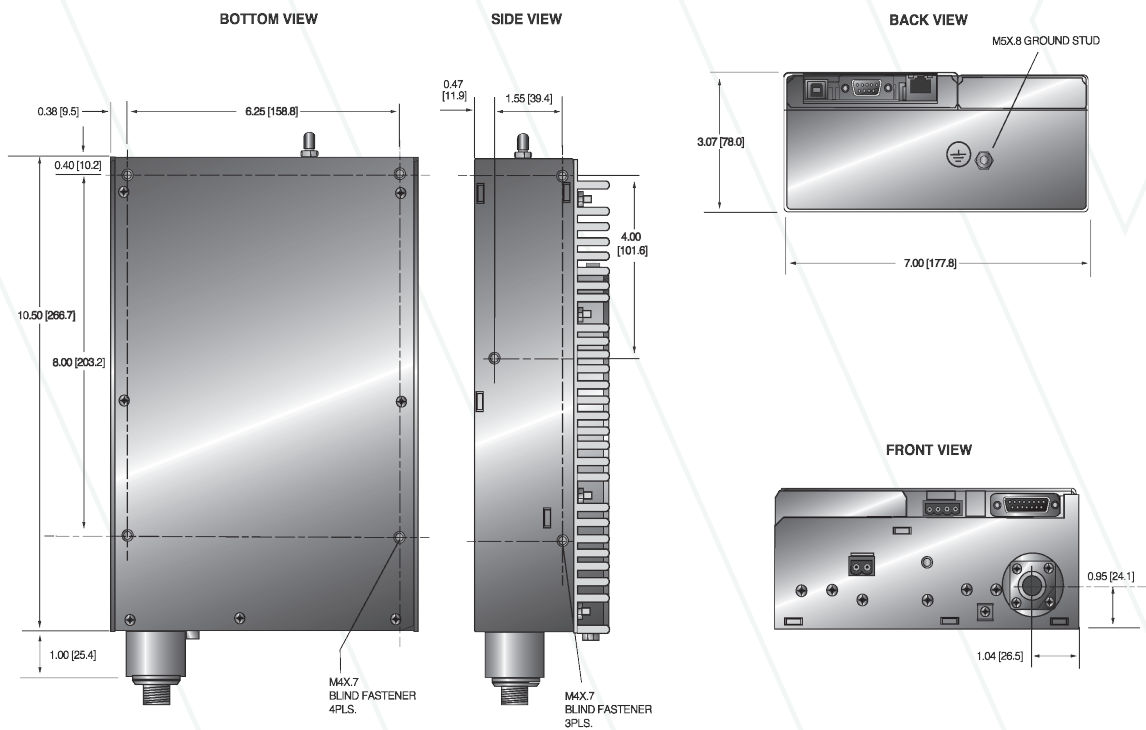

POWER/FILAMENT CONNECTOR - 4 PIN PHOENIX CONTACT

PIN	SIGNAL	PARAMETER
1	+24V Input	+24V @ 10A max
2	+24V Return	Power Ground
3	Filament Out	0.3A to 3.5A, 5V, max
4	Filament Return	Filament Return

ANALOG INTERFACE CONNECTOR

PIN	SIGNAL	PARAMETER
1	Monitor Return	Signal Ground
2	Voltage Monitor	0-10 volts = 0 to full scale, Zout=1KΩ
3	Current Monitor	0-10 volts = 0 to full scale, Zout=1KΩ
4	Interlock Output	Connect 12V HV ON bulb to pin 15 to enable
5	+10 Volt Reference	+10V at 1mA, maximum
6	Filament Monitor	1 volt = 1 amp, Zout=1KΩ
7	Voltage Program Input	0-10 volts = 0 to full scale, Zin=10MΩ
8	Local Voltage Program*	0-10 volts, screwdriver adjust
9	Filament Limit Setpoint*	1 volt = 1 amp, screwdriver adjust
10	Current Program Input	0-10 volts = 0 to full scale, Zin=10MΩ
11	Local Current Program*	10 turn pot, screwdriver adjust
12	Not used (+24V Out for Interlock)	(Optional Interlock configuration)
13	Not used (Interlock Coil)	(Optional Interlock configuration)
14	Filament Preheat Setpoint*	1 volt = 1 amp, screwdriver adjust
15	Interlock Return	Interlock Ground

*Denotes 10 turn potentiometer accessible through holes in cover

USB DIGITAL INTERFACE

PIN	SIGNAL	PARAMETER
1	VBUS	+5Vdc
2	D-	Data -
3	D+	Data +
4	GND	Ground

ETHERNET DIGITAL INTERFACE

PIN	SIGNAL	PARAMETER
1	TX+	Transmit Data +
2	TX-	Transmit Data -
3	RX+	Receive Data +
4	NC	No Connection
5	NC	No Connection
6	RX-	Receive Data -
7	NC	No Connection
8	NC	No Connection

RS-232 DIGITAL INTERFACE

PIN	SIGNAL	PARAMETER
1	NC	No Connection
2	TX out	Transmit Data
3	RX in	Receive Data
4	NC	No Connection
5	SGND	Ground
6	NC	No Connection
7	NC	No Connection
8	Voltage Monitor 2	0-10V = 0 to full scale, Zout = 1KΩ
9	Power Supply OK	+15V = OK, 0V = Fault, Sink/Source 3mA max

ALTERNATE INTERLOCK CONFIGURATION

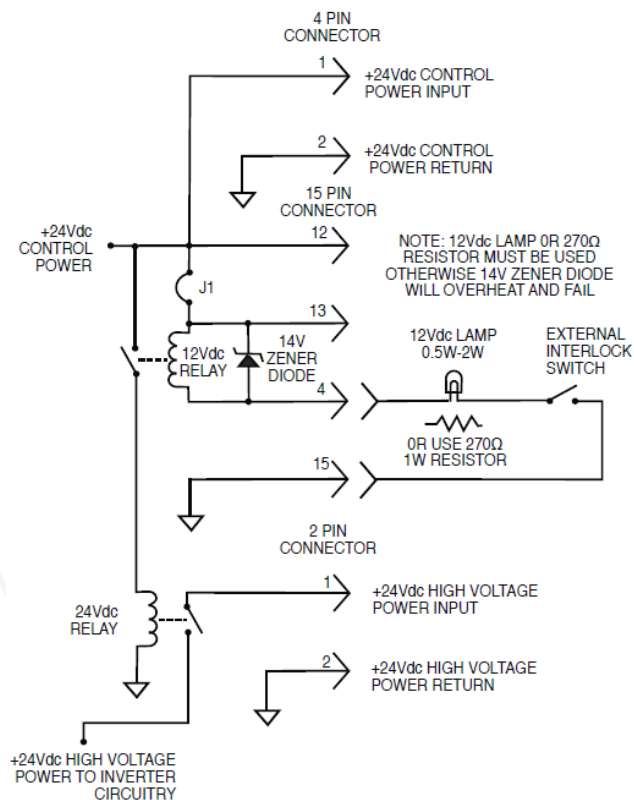

Contents in this document are subject to change without notice.

Varex Imaging Corporation

USA

HEADQUARTERS
Salt Lake City, UT
P: +1-801-972-5000

For a complete listing of our global offices,
visit www.vareximaging.com

©2020 Varex Imaging Corporation. All Rights reserved. Production of any of the material contained herein in any format or media without the express written permission of Varex Imaging Corporation is prohibited.