

Rotating Anode X-Ray Tube  
 Tubes Radiogènes à Anode Tournante  
 Röntgenröhre mit rotierender Anode  
 Tubos de Rayos-X con Ánodo Giratorio

- Common - Red  
 Neutre - Rouge  
 Neutral - Rot  
 Común - Rojo
- Large - Black  
 Grand - Noir  
 Gross - Schwarz  
 Largo - Negro
- Small -White  
 Petit - Blanc  
 Klein - Weiss  
 Pequeño - Blanco
- Stand - By  
 Attente  
 Bereitschaft  
 En Espera
- Frame or Chasis  
 Masse  
 Chassis  
 Soporte o Chasis
- X-Ray Tube  
 Tube Radiogène  
 Röntgenröhre  
 Tubo de Rayos X
- Radiation Filter or Filtration  
 Filtre de rayonnement  
 Filterung  
 Filtración de Radiación

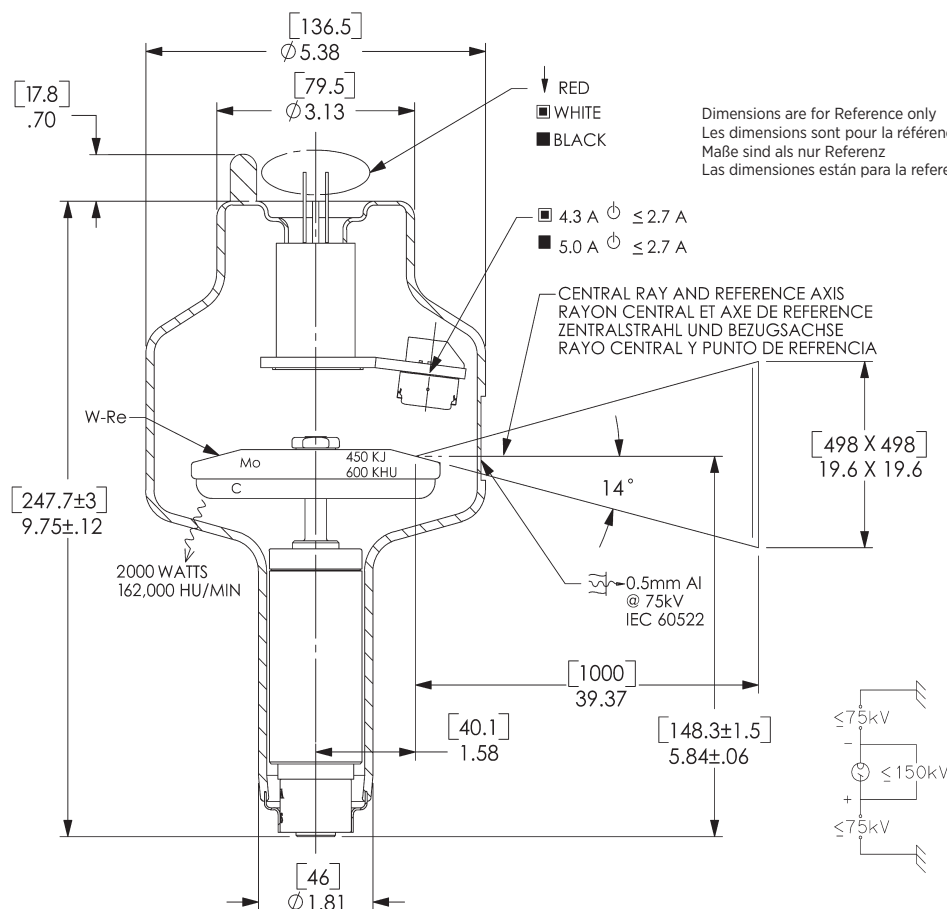

Note: Document originally drafted in the English language.

Product Description	Description du Produit	Produktbeschreibung	Descripcion del Producto
<p>The RAD-94 is a 4"(100 mm), 150 kV, 450 kJ (600 KHU) rotating anode insert specifically designed for general radiography, fluoro/spotfilm radiography, simulator work for CT extension applications and when using fluoroscopic digital systems. The insert features a 14° tungsten rhenium molybdenum graphite target and is available in the following focal spot combinations:</p> <p style="text-align: center;">0.4 - 0.8 IEC 60336</p> <p><b>Nominal Anode Input Power</b>            Small - 15 kW IEC 60613            Large - 45 kW IEC 60613            For the equivalent anode power of 190 Watts.</p>	<p>Le RAD-94 est un tube à anode tournante de 100 mm, 150 kV et 450 kJ (600 KUC) conçu tout particulièrement pour la radiographie générale et la radiographie par fluoro/spotfilm, pour simulations dans les applications par extension CT ou dans les systèmes digitaux de fluoroscopie. Il contient une anode composite en tungstène, rhénium, molybdène et graphite à pente de 14°, et est disponible dans les combinaisons focales suivantes :</p> <p style="text-align: center;">0,4 - 0,8 CEI 60336</p> <p><b>Puissance anodique nominale de l'anode</b>            Petit foyer - 15 kW CEI 60613            Grand foyer - 45 CEI 60613            Pour la puissance anodique de équivalent thermique de 190 Watts</p>	<p>Die RAD-94 ist eine Röntgenröhre mit rotierender Anode von 4"(100 mm), 150 kV und 450 kJ (600 KWE). Sie ist besonders geeignet für die allgemeine Röntgentechnik, für den Durchleuchtungsbetrieb, für die Simulator Arbeit von CT Erweiterungsanwendungen und für Durchleuchtungs Digitalsysteme. Die Röntgenröhre ist charakterisiert durch eine 14°-ige Anode, zusammengesetzt aus Wolfram, Rhenium, Molybdän und Graphit. Folgende Brennpunkte sind möglich</p> <p style="text-align: center;">0.4 - 0.8 IEC 60336</p> <p><b>Nominale Anodenbezugsleistung</b>            Klein - 15 kW IEC 60613            Gross - 45 IEC 60613            Gilt bei einer Aequivalent - Anodenleistung von 190 Watt</p>	<p>El RAD-94 es un tubo con ánodo giratorio de 100 mm (4"), 150 kV, 450 kJ (600 KUC) diseñado específicamente para radiografía general, radiografía fluoroscópica, trabajo de simulación para aplicaciones de extensión de tomografía computarizada, y para uso en sistemas digitales fluoroscópicos. El tubo presenta un objetivo de tungsteno, renio, molibdeno y grafito con una inclinación de 14°. Es disponible en las siguientes combinaciones focales:</p> <p style="text-align: center;">0.4 - 0.8 IEC 60336</p> <p><b>Potencia nominal de entrada del anodo</b>            Foco Fine - 15 kW IEC 60613            Foco grueso - 45 kW IEC 60613            Para una potencia equivalente del anodo de 190 Watts</p>

### 3 Ø Constant Potential

#### 50 Hz - 2,850 RPM

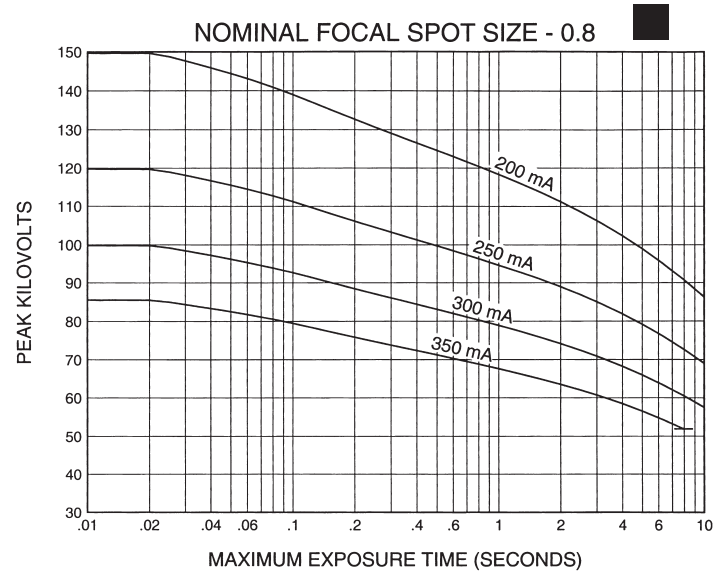
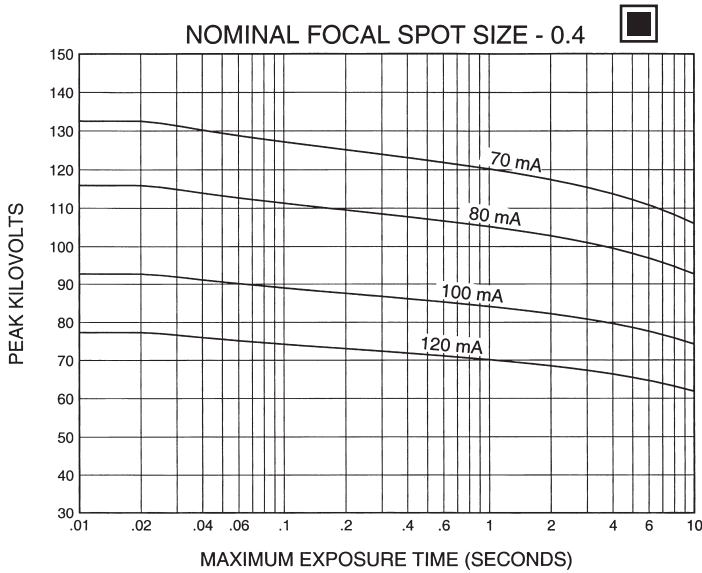

#### 60 Hz - 3,450 RPM

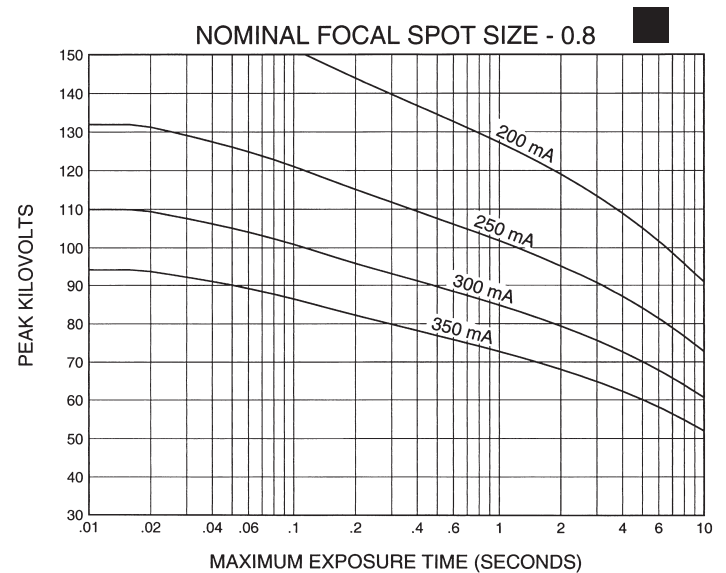
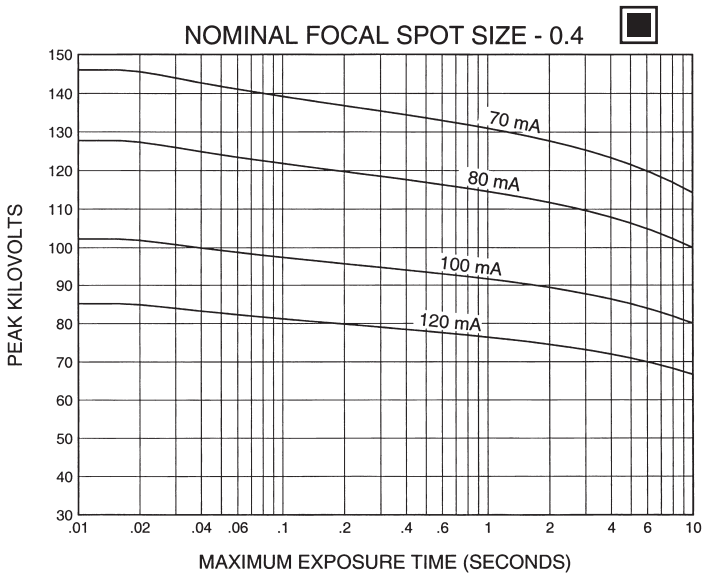

For 1Ø and other applications, please consult the manufacturer.

Pour 1Ø et autre applications, prière de consulter le Fabricant.

Für 1Ø und andere Anwendungen, konsultieren mit dem Fabrikant, bitte.

Para 1Ø y otras aplicaciones, por favor consulte a la Compañía.

Nominal anode input power for the anode heat content 40%. IEC 60613

Puissance calorifique nominale de l'anode: 40%, CEI 60613

Thermische Anodenbezugsleistung bei einer Wärmespeicherung von 40%. IEC 60613

Aproximadamente el poder de penetracion para obtener un almacenaje de calor del anodo de 40%. IEC 60613

### 3 Ø Constant Potential

#### 150 Hz - 8,500 RPM

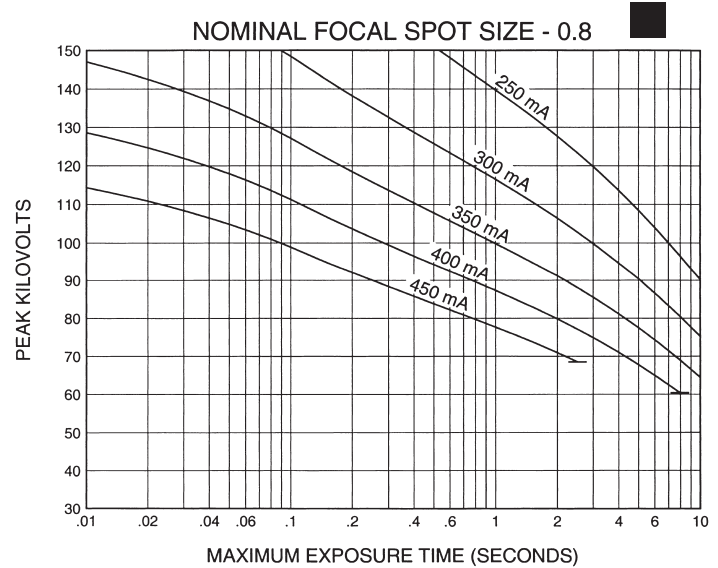
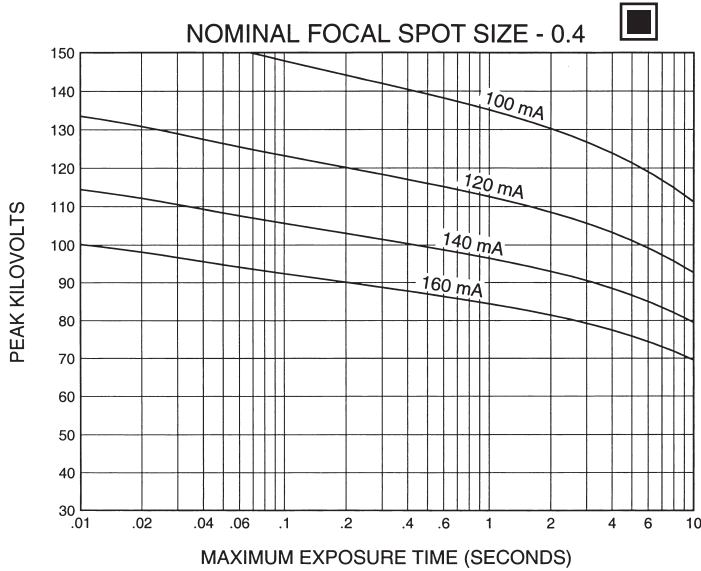

#### 180 Hz - 10,000 RPM

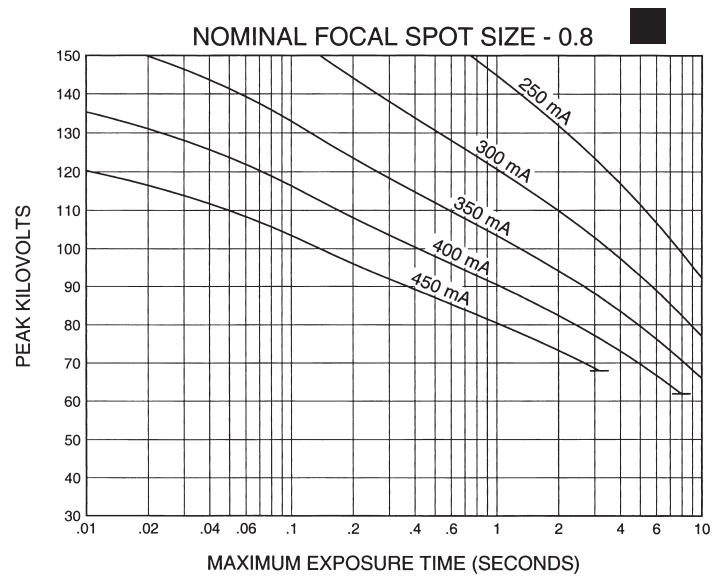
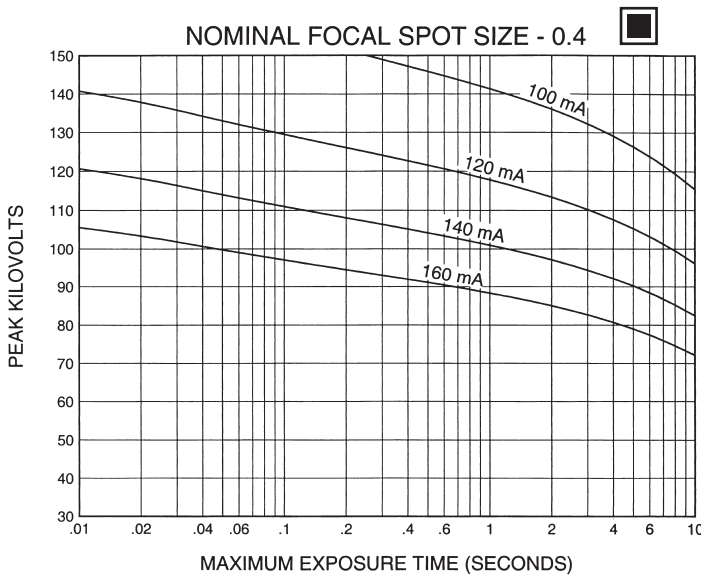

For 1Ø and other applications, please consult the manufacturer.

Pour 1Ø et autre applications, prière de consulter le Fabricant.

Für 1Ø und andere Anwendungen, konsultieren mit dem Fabrikant, bitte.

Para 1Ø y otras aplicaciones, por favor consulte a la Compañía.

Nominal anode input power for the anode heat content 40%. IEC 60613

Puissance calorifique nominale de l'anode: 40%, CEI 60613

Thermische Anodenbezugsleistung bei einer Wärmespeicherung von 40%. IEC 60613

Aproximadamente el poder de penetración para obtener un almacenaje de calor del anodo de 40%. IEC 60613

## CINERADIOGRAPHIC RATINGS

### HOW TO USE CINERADIOGRAPHIC CHARTS

**General:** With the Cineradiographic rating chart we can determine the maximum allowable kW of the Cine pulse, or with a given kW determine maximum time in seconds the Cine run can progress.

The Most common way of using the charts is to determine maximum time of any expected Cine run and maximum duty factor. With a known duty factor and Cine run time kW can easily be determined.

**Definition of Terms**

**Time in seconds:** Total time of one Cine run, usually 5 to 12 seconds.

**Duty Factor in Percent (DF%):** Actual time during one second the x-ray tube is producing x-rays. If we select a 4 msec pulse width and 60 exposures per second the x-ray tube will be producing x-rays for a total of 240 msec each second or 24% of the time. The higher the DF number, the more load placed on the x-ray tube.

**Peak Pulse Power:** Peak energy in watts of any one Cine Pulse. Can be any combination of kV and mA allowed by Radiographic and Filament Emission curves.

Example:           80 kV at 400 mA equals  
  
                          80,000 V x 0.4 A = 32,000 W or 32 kW

**USING THE CINE RATING CHARTS:**

RAD-94 150/180 Hz 3 Phase 0.8 Focal Spot

**Example:** Determine maximum kW allowed with the following known factors:  
Maximum Pulse Width ..... 4 msec  
Exposures per Second ..... 60  
Maximum Cine Run Time .....10 seconds

**Calculate Duty Factor:** (DF%)

$$DF\% = \frac{\text{Pulse Width (mSec)} \times \text{Frames per Second}}{10}$$

$$DF\% = \frac{4 \text{ msec} \times 60 \text{ exp/sec}}{10} = \frac{240}{10} = 24\%$$

Refer to Rating Chart RAD-94 150/180 Hz  
3 Phase 0.8 Focal Spot:

At bottom of chart find 10 second line. Move vertically to intersection with 24% DF curve. Make a horizontal reference to left side of rating chart and note kW rating of 34 kW.

We now know each pulse during the cine run can have a maximum rating of 34 kW under conditions given in example.

kW = kV x mA. The kW of the exposure can be any combination of mA and kV allowed by the Radiographic and Filament Emission Charts.

The Cine rating charts are usable to 100% anode heat storage. The start of Cine run should be below 70% and heat storage. Exceeding 100% anode heat storage will cause anode track erosion with high risk of tube destruction.

### 3 ∅ Constant Potential

#### 50/60 Hz

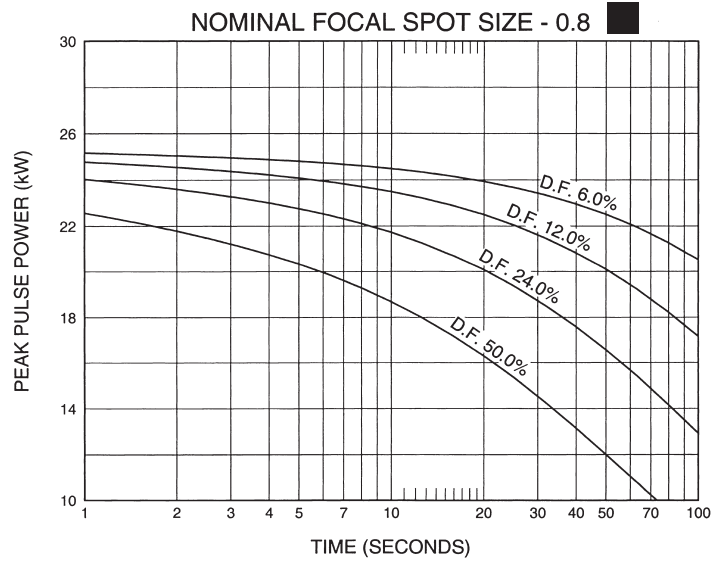
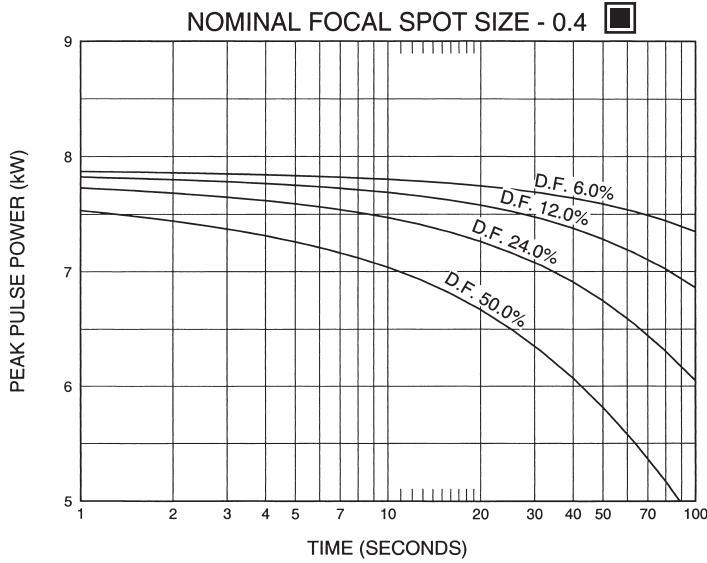

#### 150/180 Hz

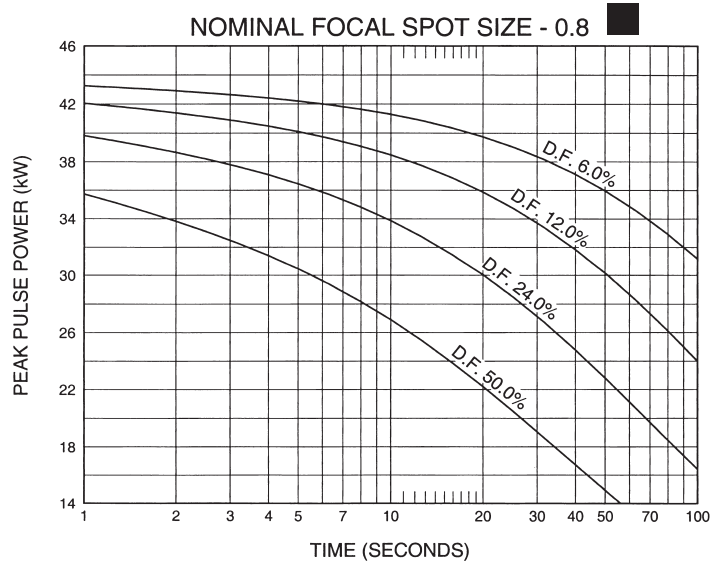
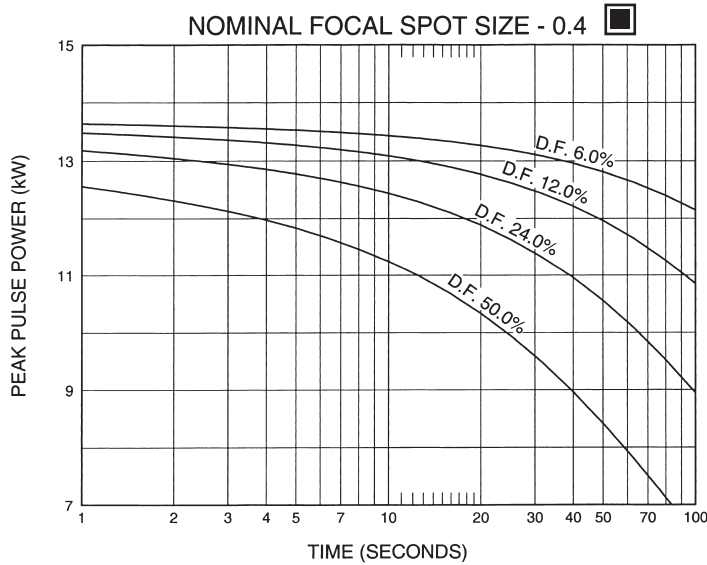

Nominal anode input power for the anode heat content 70%. IEC 60613

Puissance calorifique nominale de l'anode: 70%, CEI 60613

Thermische Anodenbezugsleistung bei einer Wärmespeicherung von 70%. IEC 60613

Aproximadamente el poder de penetración para obtener un almacenaje de calor del ánodo de 70%. IEC 60613

### 3 Ø Constant Potential

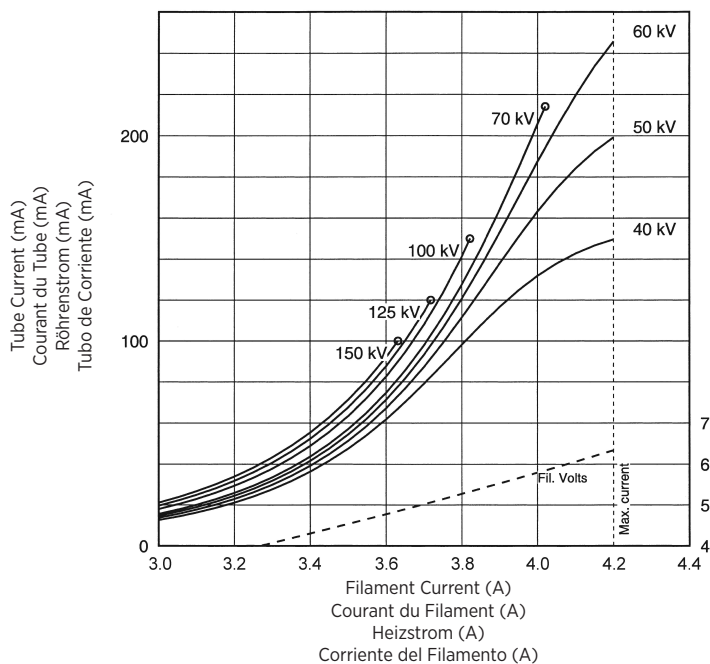

THREE PHASE EMISSION (± .15 A)

0.4 

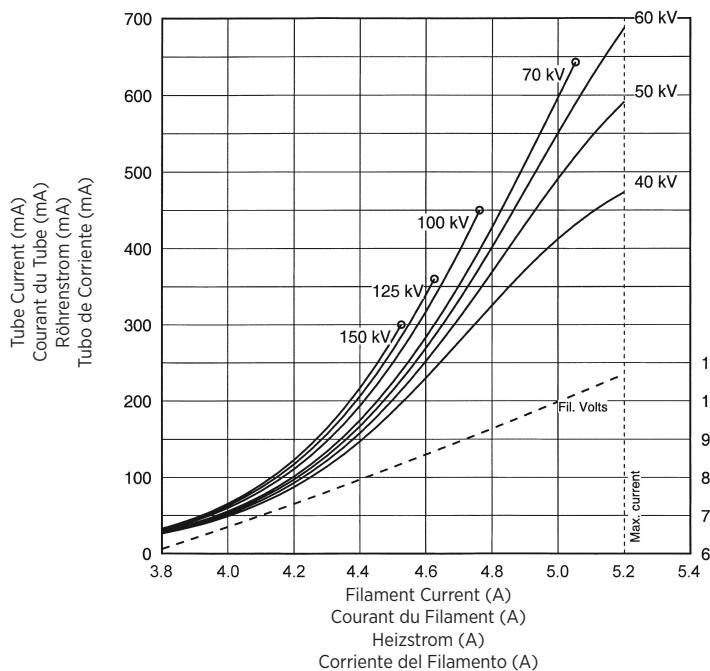

THREE PHASE EMISSION (± .15 A)

0.8 

Note:  
 When using these emission curves for trial exposures, refer to the power rating curves shown for maximum kV, tube emission, filament current, exposure time, and target speed.

Remarque:  
 Lors de l'utilisation de ces abaques pour des expositions d'essai, référez-vous aux courbes maximales de kV, d'émission du filament, de temps d'exposition et de vitesse de rotation.

Anmerkung:  
 Wenn Sie diese Emissionskurven für Testaufnahmen verwenden, beziehen Sie sich hierbei auf die entsprechenden Nennleistungskurven für max. kV-Werte, Röhrenemission, Heizstrom, und Anodendrehzahl.

Nota:  
 Si utiliza estas curvas de emisión para exposiciones de prueba, refiérase a las curvas de gradación de potencia para el máximo de kV, tubo de emisión, corriente en los filamentos, tiempo de exposición, y a las curvas de velocidad del objetivo.

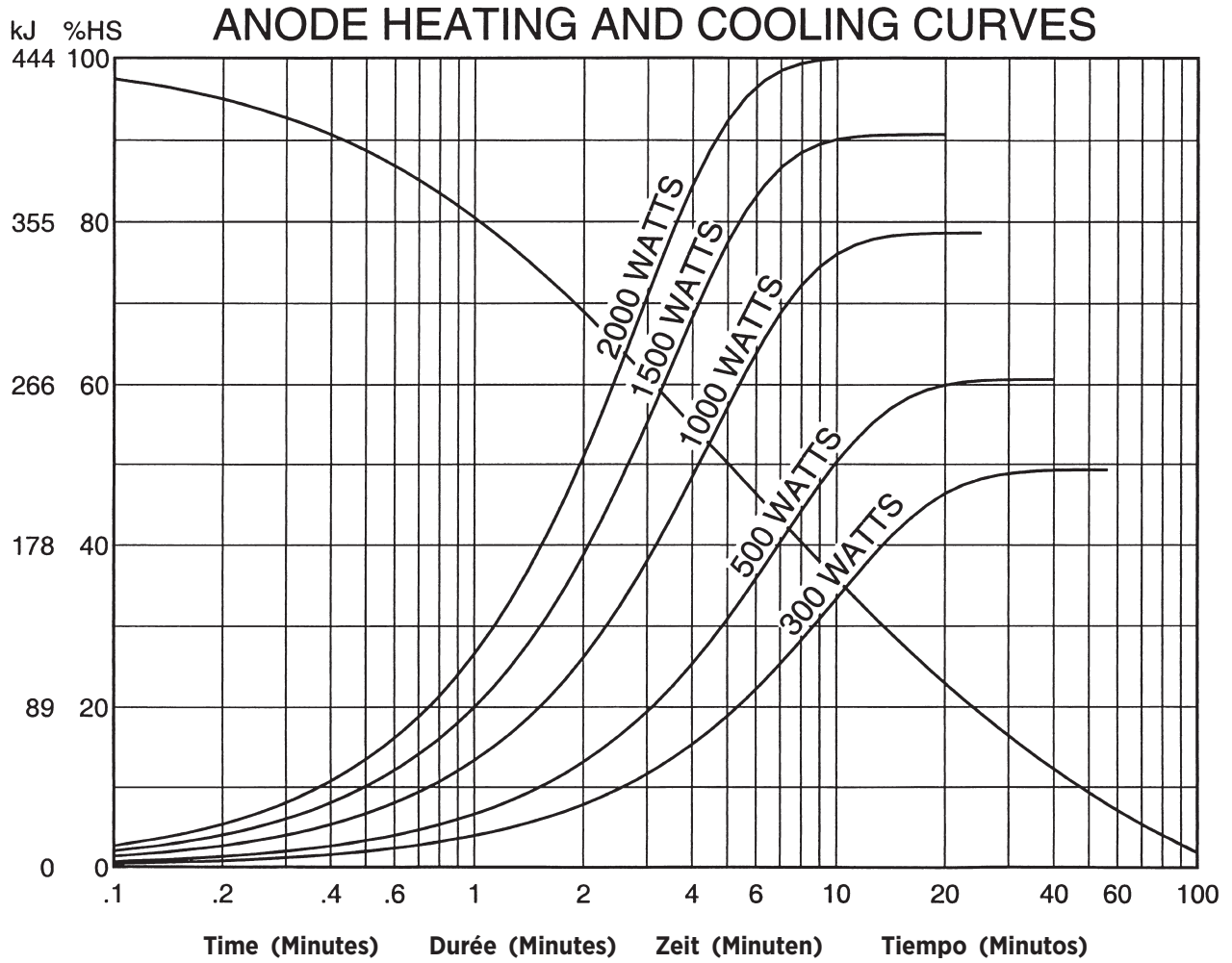



Salt Lake City, UT 1-801-972-5000

For a complete listing of our global offices,  
visit [www.vareximaging.com](http://www.vareximaging.com)

Manufactured by Varex Imaging Corporation  
Fabrique par Varex Imaging Corporation  
Hergestellt von Varex Imaging Corporation  
Fabricado por Varex Imaging Corporation

Specifications subject to change without notice.  
Spécifications susceptibles d'être modifiées sans préavis.  
Technische Daten ohne Gewähr.  
Especificaciones sujetas a cambio sin previo aviso.