

DICOM 3.0 Conformance Statement for Varex Nexus DRF Systems

Engineering
Technical Support
Quality Assurance



Table of Contents

0.0 Revisions..... 2
1.0 Purpose..... 2
2.0 Scope..... 2
3.0 References and Forms..... 2
4.0 Equipment and Materials 2
5.0 Responsibilities 2
6.0 Definitions..... 2
7.0 Instructions..... 3

DICOM 3.0 Conformance Statement for Varex Nexus DRF Systems

Engineering

Technical Support

Quality Assurance



0.0 Revisions

[Click Here to view Revisions](#)

1.0 Purpose

Define the DICOM Conformance statement associated with Varex Nexus DRF systems.

2.0 Scope

This document describes the DICOM Conformance statement in accordance with the document DICOM PS 3.2 Conformance.

3.0 References and Forms

DICOM 2011

DICOM PS 3.1 Introduction and Overview

DICOM PS 3.2 Conformance

DICOM PS 3.3 Information Object Definitions

DICOM PS 3.4 Service Class Specifications

DICOM PS 3.5 Data Structures and Encoding

DICOM PS 3.6 Data Dictionary

DICOM PS 3.7 Message Exchange

DICOM PS 3.8 Network Communication Support for Message Exchange

DICOM PS 3.10 Media Storage and File Format for Media Interchange

DICOM PS 3.11 Media Storage Application Profiles

DICOM PS 3.12 Media Formats and Physical Media for Media Interchange

DICOM PS 3.14 Grayscale Standard Display Function

4.0 Equipment and Materials

N/A

5.0 Responsibilities

N/A

6.0 Definitions

AE	Application Entity
FSC	File Sector Creator
FSR	File Sector Reader
FSU	File Sector Updater
IOD	Information Object Definition
SCU	Service Class User
SCP	Service Class Provider
SOP	Service Object Pair
UID	Unique Identifier

DICOM 3.0 Conformance Statement for Varex Nexus DRF Systems
Engineering
Technical Support
Quality Assurance



7.0 Instructions

The rest of this document is written in the format specified for DICOM Conformance statements in the DICOM PS 3.2 Conformance standard document.

DICOM 3.0 Conformance Statement for Varex Nexus DRF Systems	
Engineering	
Technical Support	
Quality Assurance	

8.0 Introduction

This conformance statement details the Varex Nexus DRF system’s compliance to DICOM 3.0. It covers all service class roles that are supported by this product:

- Storage Service Class (SCU) roles
- Storage Commitment Service Class (SCU) roles
- Verification Service Class (SCU) roles
- Modality Worklist Management Service Class (SCU) roles

8.1 Implementation Model

DICOM capabilities of the NEXUS system include:

The NEXUS system can send images to a remote AE by initiating the DICOM C-STORE request as a SCU.

The NEXUS system can act as a Storage Commitment SCU to request commitment for images transferred to a remote AE.

The NEXUS system supports the DICOM Verification operation as a SCU.

The NEXUS system can query DICOM Modality Worklist SCP systems for patient/study information using the Modality Worklist Management Service Class.

The NEXUS system can report back Performed Procedure information to a Modality Worklist SCP using the Modality Performed Procedure Step service.

The NEXUS system can send images to a DICOM Print Server AE by utilizing the services of the Basic Grayscale Print Management Meta SOP Class as a SCU.

The NEXUS system can store images for interchange using the General Purpose CD-R Image Interchange Profile Class.

8.1.1 Application Data Flow Diagrams

See figures 8.1.1-1, 8.1.1-2.

DICOM 3.0 Conformance Statement for Varex Nexus DRF Systems

Engineering
Technical Support
Quality Assurance



Figure 8.1.1-1 Storage SCU

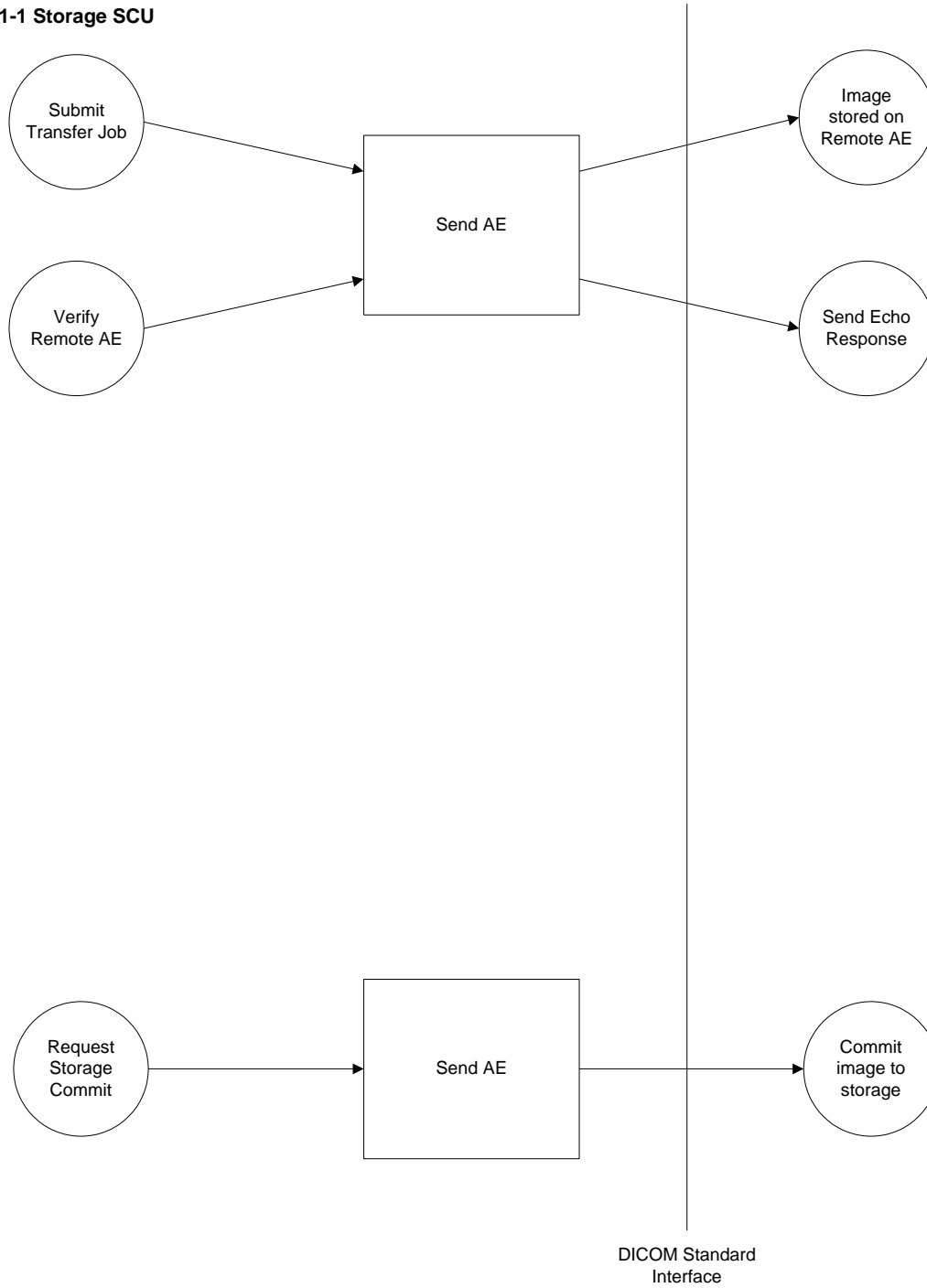

DICOM 3.0 Conformance Statement for Varex Nexus DRF Systems

Engineering
Technical Support
Quality Assurance



8.1.1-2 Print SCU

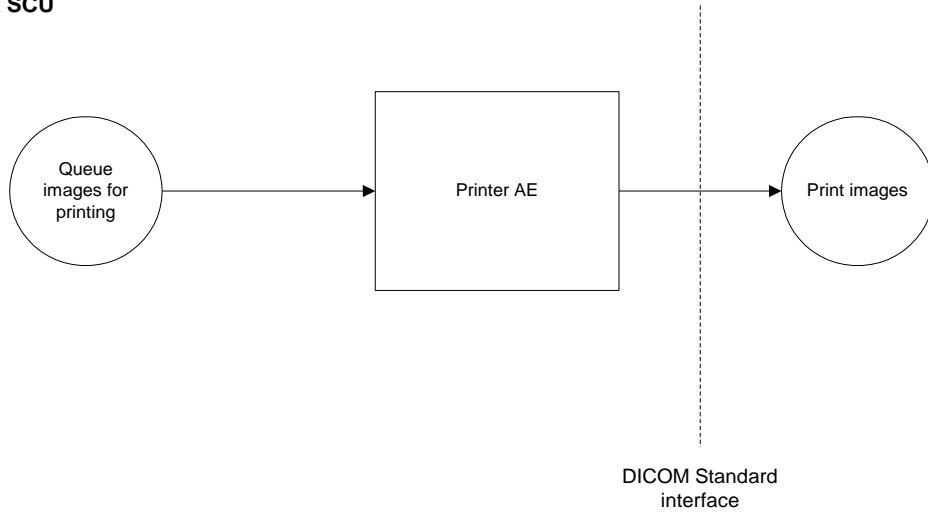

8.1.1-3 Worklist and MPPS SCU

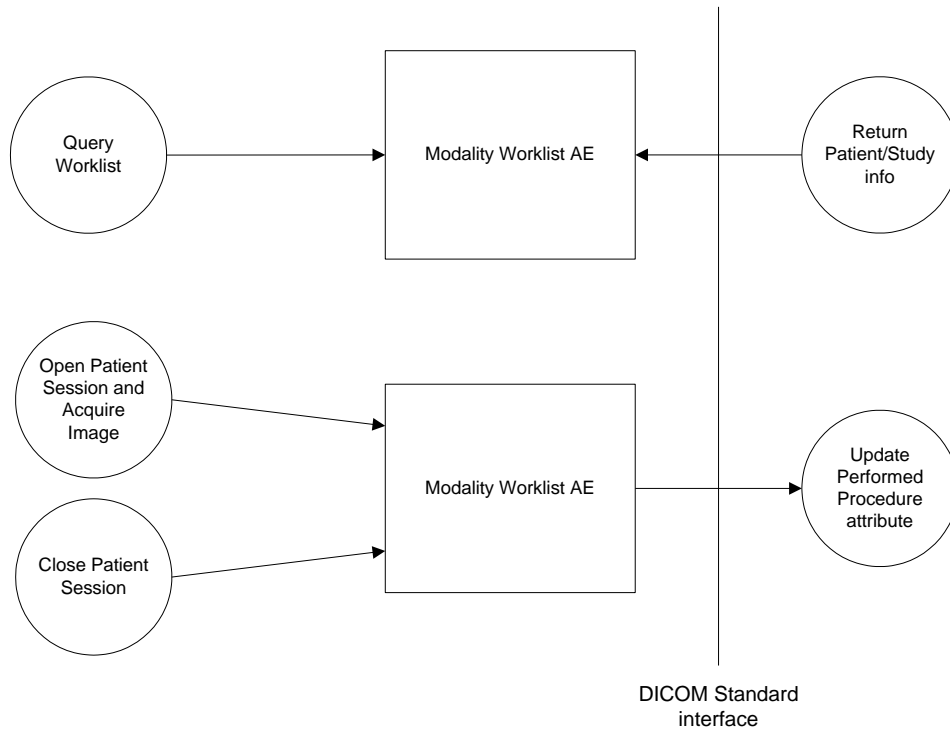

DICOM 3.0 Conformance Statement for Varex Nexus DRF Systems

Engineering
Technical Support
Quality Assurance



8.1.1-4 Media Storage AE

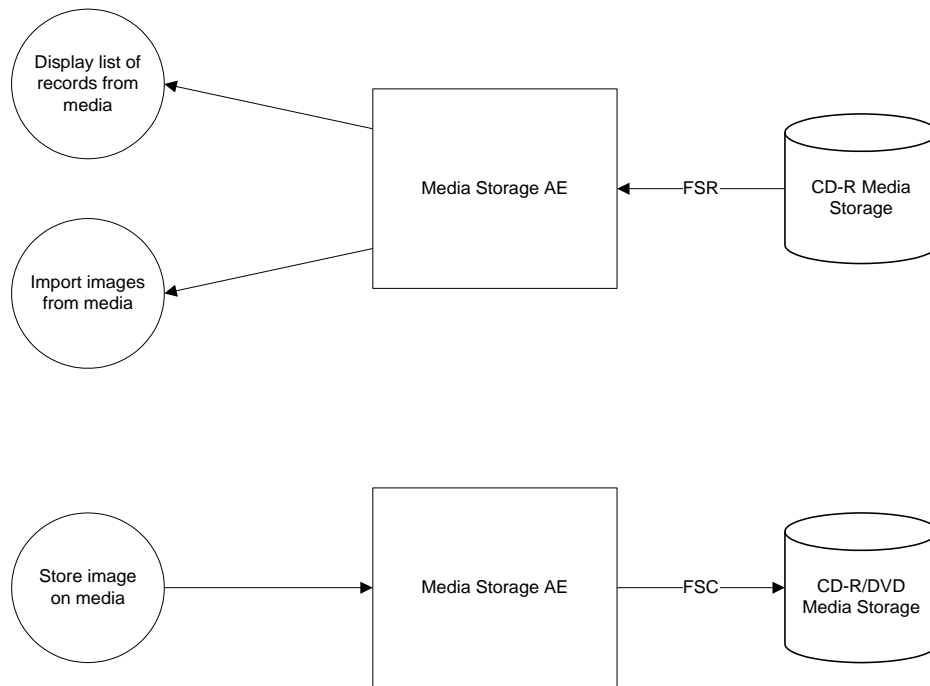

8.1.2 Functional definition of AEs

Send AE:

The Send AE initiates an association with a remote AE and acts as a SCU of the Storage Service Class to store images on a remote AE that acts as a SCP of the Storage Service Class.

When the image transfer is completed, the send function waits for the DIMSE-C-STORE Response from the receiving AE to indicate the status of the transfer (success or fail).

The Send AE can also request Storage Commitment for images that it transfers to a remote AE if the remote AE is configured for the Storage Commit Service as a SCP.

When the Send AE system initiates the DICOM Echo Request, it first proposes an Association with the Verification Class Presentation Context. When the DICOM Association Accept message

DICOM 3.0 Conformance Statement for Varex Nexus DRF Systems	
Engineering	
Technical Support	
Quality Assurance	

is received, the system sends the DIMSE-C-ECHO Request message to initiate the Verification function on the receiving AE. The status of the Verification response (success or fail) is displayed.

Modality Worklist AE:

The Modality Worklist AE initiates an Association with a user selected remote Worklist AE and acts as a SCU of the Modality Worklist Management Service Class. The Modality Worklist AE sends a C-FIND request based on parameters set by the user. The user can configure the Modality Worklist AE to query for any/all modalities supported by the local system. The user can configure the Worklist to query for exams scheduled for any AE configured in the system as a Worklist SCU. One request is sent for each modality/AE title pair configured by the user.

If the remote Worklist AE supports the Modality Performed Procedure Step service then the Modality Worklist AE can be used to notify the remote AE of Performed Procedure Step updates (In Progress, Discontinued, Completed).

Print AE:

The Print AE initiates an Association with a user selected remote Print AE and acts as a SCU of the Basic Grayscale Print Management Service Class. When all of the images for a particular Film Session have been transferred, the Association is closed.

Media Storage AE:

The Media Storage AE can perform the following functions:

1. It can initialize a piece of media, writing a new DICOM File-set onto the media.
2. It can display a directory listing of the File-set on a piece of media.
3. It can copy SOP instances from the media onto local storage.

8.1.3 Sequencing of Real World Activities

8.1.3.1 Print Operations

The following describes the sequence of events that occurs when performing a print operation:

1. The user queues up a print job from the GUI.
2. The Print AE sends a DICOM Association Request to the print server AE.
3. If the DICOM Association request fails then the print job is aborted.
4. If the DICOM Association request is successful then the Print AE requests the printer status with the Printer N-GET message.
 - a. NORMAL – Continue with print operation.
 - b. FAILURE – The print job is aborted.
5. The Print AE sends the Basic Film Session N-CREATE message to the print server and waits for the N-CREATE Response.
 - a. SUCCESS – Continue print operation.
 - b. FAILURE – The print job is aborted.
6. The Print AE sends the Basic Film Box N-CREATE message to the print server and waits for the N-CREATE Response.
 - a. SUCCESS – Continue print operation.
 - b. FAILURE (C616) – The print job is aborted.

DICOM 3.0 Conformance Statement for Varex Nexus DRF Systems

Engineering

Technical Support

Quality Assurance



7. The Print AE sends an Image Box N-SET message to the print server and waits for the N-SET response.
 - a. SUCCESS – Continue print operation.
 - b. FAILURE (C603, C605, C613) – The print job is aborted.
8. When the Film Box is full or the last image in the print job has been added to the Film Box then the Print AE sends a Film Box N-ACTION message to the print server and waits for the N-ACTION response.
 - a. SUCCESS – Continue with print operation.
 - b. FAILURE (C602, C603, C613) – The print job is aborted.
9. When the print job is completed (or aborted) the Print AE sends a DICOM Association Release Request to the print server.

8.1.3.2 Storage Operations

The following describes the sequence of events that occurs when performing a storage operation with a network storage server AE:

1. The user queues up a send job from the GUI.
2. The Send AE sends a DICOM Association Request to the storage server AE.
3. If the DICOM Association request fails then the send job is aborted.
4. If the DICOM Association request is successful then the Send AE sends a C-STORE Request message to the storage server and waits for the C-STORE response.
 - a. SUCCESS – Continue with send operation.
 - b. WARNING – Continue with send operation.
 - c. FAILURE (0110, A700, A900, C000, C002) – The send job is aborted. The Send AE sends a DICOM Association Abort Request message to the storage server AE.
5. When the send job is completed the Send AE sends a DICOM Association Release Request to the storage server AE.

8.1.3.3 Worklist Operations

The following describes the sequence of events that occurs when performing a worklist operation with a worklist server AE:

1. The user initiates a Worklist query from the GUI.
2. The Worklist AE sends a DICOM Association Request to the worklist server AE.
3. If the DICOM Association request fails then the status display on the GUI indicates that the Association failed.
4. If the DICOM Association request is successful then the Worklist AE sends a C-FIND Request message to the worklist server and waits for a C-FIND response.
 - a. SUCCESS – C-FIND is completed.
 - b. PENDING (FF00, FF01) – Matches are continuing. If the number of matches exceeds the maximum defined by the user then the Worklist AE sends a C-CANCEL Request message to the worklist server.
 - c. CANCEL (FE00) – C-FIND is cancelled.
 - d. FAILED (A900, Cxxx) – The Worklist AE sends a DICOM Association Abort Request to the worklist server.
5. For the SUCCESS and CANCEL cases, the Worklist AE sends a DICOM Association Release Request to the worklist server. The status display on the GUI indicates that the worklist query is completed and the list of matching records is displayed.

8.1.3.4 Modality Performed Procedure Step Operations

DICOM 3.0 Conformance Statement for Varex Nexus DRF Systems

Engineering

Technical Support

Quality Assurance



The following describes the sequence of events that occurs when performing a MPPS operation with a MPPS server AE:

1. The user opens an empty Patient/Study and acquires the first image.
2. The MPPS AE sends a DICOM Association Request to the MPPS server AE.
3. If the DICOM Association request fails then the MPPS operation is aborted.
4. If the DICOM Association request is successful then the MPPS AE sends a Modality Performed Procedure Step N-CREATE Request message to the MPPS server AE and waits for a N-CREATE response.
 - a. SUCCESS – Continue with MPPS operation.
 - b. FAILURE – MPPS operation is terminated.
5. The MPPS AE sends a DICOM Association Release Request to the MPPS server AE.
6. The user acquires additional images into the Patient/Study and then closes the Patient/Study.
7. The MPPS AE sends a DICOM Association Request to the MPPS server AE.
8. If the DICOM Association request fails then the MPPS operation is aborted.
9. If the DICOM Association request is successful then the MPPS AE sends a Modality Performed Procedure Step N-SET Request message to the MPPS server AE and waits for the N-SET response.
 - a. SUCCESS – MPPS operation is successfully completed.
 - b. FAILURE – MPPS operation is terminated.
10. The MPPS AE sends a DICOM Association Release request to the MPPS server AE.

8.1.4 File Meta Information Options

Implementation Class UID = “1.2.840.113698. 7.1”

Implementation Version Name = “InfiView_101”

The Implementation Class UID is part of the File Meta Information written into every file and therefore necessary for any device that acts as an FSC.

8.2 AE Specifications

8.2.1 Send AE - Specification

The Send AE provides Standard Conformance to the following DICOM V3.0 SOP Classes as a SCU:

SOP Class Name	SOP Class UID
Verification SOP Class	1.2.840.10008.1.1
Secondary Capture Image Storage	1.2.840.10008.5.1.4.1.1.7
X-Ray Angiographic Image Store	1.2.840.10008.5.1.4.1.1.12.1
X-Ray RF Image Store	1.2.840.10008.5.1.4.1.1.12.2
Storage Commitment Push Model	1.2.840.10008.1.20.1
Key Object Selection Storage	1.2.840.10008.5.1.4.1.1.88.59
Digital XRay Image Storage For Presentation	1.2.840.10008.5.1.4.1.1.1.1
Digital XRay Image Storage For Processing	1.2.840.10008.5.1.4.1.1.1.1.1
X-Ray Radiation Dose SR Storage	1.2.840.10008.5.1.4.1.1.88.67

8.2.1.1 Association establishment policies

8.2.1.1.1 General

The DICOM Application Context name is 1.2.840.10008.3.1.1.1

The AE Title of the Send AE is a configurable parameter. The default title is “OEM_StoreSCU”.

The Send AE establishes an association whenever a transfer job comes to the top of the transfer queue.

If the remote AE that stores the images is configured for the Storage Commit service then the Send AE establishes an association after a transfer job is successfully completed to request storage commitment.

The Send AE establishes an association whenever the user attempts to verify the DICOM connection with a remote AE.

The maximum PDU size is 30720 bytes.

8.2.1.1.2 Number of Associations

The Send AE attempts only one Association establishment at a time.

8.2.1.1.3 Asynchronous nature

The Send AE does not perform asynchronous operations.

8.2.1.1.4 Implementation Identifying Information

The Send AE provides a single Implementation Class UID which is “1.2.840.113698.7.1”.

8.2.1.2 Association initiation policy

The Send AE initiates a new association for the DIMSE-C-STORE service operation for each transfer job that comes to the top of the job queue.

The Send AE initiates a new association for the DIMSE-C-ECHO service operation.

8.2.1.2.1 Transfer Image Object to a Remote AE

8.2.1.2.1.1 Associated Real-World Activity – Queue image(s) for transfer to remote AE

The associated Real-World activity is a C-Store Request initiated by the Send AE when a transfer job comes to the top of the job queue. A transfer job is created by the user selecting a study or group of studies to be sent to a remote AE.

8.2.1.2.1.2 Proposed presentation contexts

The Send AE proposes Presentation Contexts as shown in [Table 8.2.1.2.1.2-1](#).

The receiving AE returns which Presentation Contexts it supports in the Association Accept message.

Table 8.2.1.2.1.2-1 Proposed Presentation Contexts for Send AE

Presentation Context Table					
Abstract Syntax		Transfer Syntax		Role	Extended Negotiation
Name	UID	Name List	UID List		
X-Ray Angiographic Image Store	1.2.840.10008.5.1.4.1.1.12.1	DICOM Implicit VR Little Endian	1.2.840.10008.1.2	SCU	None
		DICOM Explicit VR Little Endian	1.2.840.10008.1.2.1	SCU	None
		DICOM JPEG Lossless, Nonhierarchical, First- Order Prediction	1.2.840.10008.1.2.4.70	SCU	None
		DICOM RLE Lossless	1.2.840.10008.1.2.5	SCU	None
X-Ray RF Image Store	1.2.840.10008.5.1.4.1.1.12.2	DICOM Implicit VR Little Endian	1.2.840.10008.1.2	SCU	None
		DICOM Explicit VR Little Endian	1.2.840.10008.1.2.1	SCU	None
		DICOM JPEG Lossless, Nonhierarchical, First- Order Prediction	1.2.840.10008.1.2.4.70	SCU	None

DICOM 3.0 Conformance Statement for Varex Nexus DRF Systems



Engineering
 Technical Support
 Quality Assurance

Presentation Context Table					
Abstract Syntax		Transfer Syntax		Role	Extended Negotiation
Name	UID	Name List	UID List		
		DICOM RLE Lossless	1.2.840.10008.1.2.5	SCU	None
Storage Commitment Push Model	1.2.840.10008.1.20.1	DICOM Implicit VR Little Endian	1.2.840.10008.1.2	SCU	None
		DICOM Explicit VR Little Endian	1.2.840.10008.1.2.1	SCU	None
Verification Service Class	1.2.840.10008.1.1	DICOM Implicit VR Little Endian	1.2.840.10008.1.2	SCU	None
		DICOM Explicit VR Little Endian	1.2.840.10008.1.2.1	SCU	None
Digital XRay Image Storage For Presentation	1.2.840.10008.5.1.4.1.1.1.1	DICOM Implicit VR Little Endian	1.2.840.10008.1.2	SCU	None
		DICOM Explicit VR Little Endian	1.2.840.10008.1.2.1	SCU	None
		DICOM JPEG Lossless, Nonhierarchical, First- Order Prediction	1.2.840.10008.1.2.4.70	SCU	None
		DICOM RLE Lossless	1.2.840.10008.1.2.5	SCU	None
Digital XRay Image Storage For Presentation	1.2.840.10008.5.1.4.1.1.1.1	DICOM Implicit VR Little Endian	1.2.840.10008.1.2	SCU	None
		DICOM Explicit VR Little Endian	1.2.840.10008.1.2.1	SCU	None
		DICOM JPEG Lossless, Nonhierarchical, First- Order Prediction	1.2.840.10008.1.2.4.70	SCU	None
		DICOM RLE Lossless	1.2.840.10008.1.2.5	SCU	None
X-Ray Radiation Dose SR Storage	1.2.840.10008.5.1.4.1.1.88.67	DICOM Implicit VR Little Endian	1.2.840.10008.1.2	SCU	None
		DICOM Explicit VR Little Endian	1.2.840.10008.1.2.1	SCU	None

8.2.1.2.1.2.1 SOP Specific Conformance

When a successful response to a C-STORE operation is received, the status display is updated to indicate that the percentage of job that has been transferred at that point .

DICOM 3.0 Conformance Statement for Varex Nexus DRF Systems	
Engineering	
Technical Support	
Quality Assurance	

If an Association request fails or if a Failed, Refused or Warning response to a C-STORE operation is received then the currently active transfer job is put into an error state.

Extended negotiation is not supported.

See [Annex A](#) for a description of the IOD modules supported.

8.2.1.2.2 Send Storage Commit Request to Remote AE

8.2.1.2.2.1 Associated Real-World Activity – Request Storage Commit for previously transferred images

The associated Real-World activity is a N-Action Request initiated by the Send AE with a list of UIDs for the images from a successfully completed transfer job.

8.2.1.2.2.2 Proposed presentation contexts

The Send AE proposes Presentation Contexts as shown in [Table 8.2.1.2.1.2-1](#).

The receiving AE returns which Presentation Contexts it supports in the Association Accept message.

8.2.1.2.2.2.1 SOP Specific Conformance

If a transfer job is completed successfully and the remote AE that the images were sent to is configured for the Storage Commit Service as a SCP then the Send AE initiates a Storage Commit Request message for the images in the transfer job. If the Storage Commit request is successful for an image then the local database record for that image indicates that the image has been archived.

Extended negotiation is not supported.

8.2.1.2.3 Send Echo Request to Remote AE

8.2.1.2.3.1 Associated Real-World Activity - Verify DICOM connection with remote AE

The associated Real-World activity is a C-Echo Request initiated by the user to determine if a remote DICOM AE is responding.

8.2.1.2.3.2 Proposed presentation contexts

The Send AE proposes a Presentation Context as shown in [Table 8.2.1.2.1.2-1](#).

8.2.1.2.3.2.1 SOP Specific Conformance

The Send AE provides standard conformance to the DICOM Verification Service Class as a SCU.

8.2.1.3 Association acceptance policy

The Send AE is always ready to accept associations for the purpose of receiving a verification request or a storage commit response (N-EVENT-REPORT). The default port for listening for these events is 2400.

8.2.2 Modality Worklist AE - Specification

The Modality Worklist AE provides Standard Conformance to the following DICOM V3.0 SOP Classes as a SCU:

SOP Class Name	SOP Class UID
Modality Worklist Find	1.2.840.10008.5.1.4.31
Modality Performed Procedure Step	1.2.840.10008.3.1.2.3.3
Verification SOP Class	1.2.840.10008.1.1

8.2.2.1 Association establishment policies

8.2.2.1.1 General

The DICOM Application Context name is 1.2.840.10008.3.1.1.1

The AE Title of the Modality Worklist AE is a configurable parameter. The default title is “OEM_WorklistSCU”.

The Modality Worklist AE establishes associations under the following conditions:

1. When the user initiates a manual query.
2. To create a Modality Performed Procedure Step notification object
3. When the user attempts to verify the DICOM connection with a remote Worklist AE

The maximum PDU size is 30720 bytes.

8.2.2.1.2 Number of Associations

The Modality Worklist AE can have one Association open at one time.

8.2.2.1.3 Asynchronous nature

The Modality Worklist AE does not perform asynchronous operations.

8.2.2.1.4 Implementation Identifying Information

The Modality Worklist AE provides a single Implementation Class UID which is “1.2.840.113698.7.1”.

8.2.2.2 Association initiation policy

The Modality Worklist AE initiates a new association for the Worklist Management Class for each query session. A query session is defined as a group of queries required to completely satisfy the input from the user. The Association is closed when all of the results from the query session have been received.

If Patient/Study information was received from a worklist SCP then the Modality Worklist AE initiates a new association to handle the Performed Procedure Step Notification service when the Patient/Study record is “opened” for image acquisition and the first image is acquired.

The Modality Worklist AE initiates a new association to verify a DICOM connection with a remote Worklist AE when the user selects the echo option for the remote AE.

8.2.2.2.1 Worklist Query Operations

The Modality Worklist AE initiates associations to perform C-FINDs and Performed Procedure Step notifications. The association is closed after an error or when the initiator requests that it be closed.

8.2.2.2.1.1 Associated Real-World Activity – Query for Scheduled Procedure information

Once the Worklist Query association has been established, the Modality Worklist AE sends a series of Worklist C-FIND messages to the Worklist SCP. One C-FIND message is sent for each Modality selected by the user. After each C-FIND message is sent, the Modality Worklist AE waits for a C-FIND response from the SCP. If the total number of records received during the active association exceeds the maximum limit set by the user, a C-CANCEL-FIND message is sent to the SCP. Response messages are read in until a C-FIND response of Success is received.

8.2.2.2.1.2 Proposed presentation contexts

The Presentation Contexts proposed by the Modality Worklist AE are defined in [table 8.2.2.2.1.2-1](#).

Table 8.2.2.2.1.2-1 Proposed Presentation Contexts for Modality Worklist AE

Presentation Context Table					
Abstract Syntax		Transfer Syntax		Role	Extended Negotiation
Name	UID	Name List	UID List		
Modality Worklist Find	1.2.840.10008.5.1.4.31	DICOM Implicit VR Little Endian	1.2.840.10008.1.2	SCU	None
		DICOM Explicit VR Little Endian	1.2.840.10008.1.2.1	SCU	None
Modality Performed Procedure Step	1.2.840.10008.3.1.2.3.3	DICOM Implicit VR Little Endian	1.2.840.10008.1.2	SCU	None
		DICOM Explicit VR Little Endian	1.2.840.10008.1.2.1	SCU	None
Verification Service Class	1.2.840.10008.1.1	DICOM Implicit VR Little Endian	1.2.840.10008.1.2	SCU	None
		DICOM Explicit VR Little Endian	1.2.840.10008.1.2.1	SCU	None

DICOM 3.0 Conformance Statement for Varex Nexus DRF Systems	
Engineering	
Technical Support	
Quality Assurance	

8.2.2.2.1.2.1 SOP Specific Conformance

The Modality Worklist AE provides standard conformance to the DICOM Modality Worklist Find Service Class as a SCU.

See Annex B for a description of the attribute values for the Modality Worklist Find operation proposed by the Modality Worklist AE.

Extended negotiation is not supported.

8.2.2.2.2 Worklist Performed Procedure Step Operations

8.2.2.2.2.1 Associated Real-World Activity – Notify Remote AE of Performed Procedure Step Status

8.2.2.2.2.2 Proposed presentation contexts

The Presentation Contexts proposed by the Modality Worklist AE are defined in [table 8.2.2.2.1.2-1](#).

8.2.2.2.2.1 SOP Specific Conformance

The Modality Worklist AE provides standard conformance to the DICOM Modality Performed Procedure Step Service Class as a SCU.

When the system opens a Patient/Study/Series record for image acquisition and acquires an image, if the patient information was received from a remote Worklist AE and if the system has been configured for the Performed Procedure Step service then the Modality Worklist AE will attempt to establish an Association to create and update a Performed Procedure Step object.

When the patient is closed, a new association is created to update the Performed Procedure Step object with a status of “completed” or “discontinued.”

Extended negotiation is not supported.

8.2.2.2.2 Verify DICOM Connection with Worklist SCP

8.2.2.2.2.1 Associated Real-World Activity – User selects verify option for a remote Worklist AE

When the user selects the Echo option for a selected remote Worklist AE the Modality Worklist AE initiates an Association to execute the Verification Service class.

8.2.2.2.2.2 Proposed presentation contexts

The Presentation Contexts proposed by the Modality Worklist AE are defined in [table 8.2.2.2.1.2-1](#).

DICOM 3.0 Conformance Statement for Varex Nexus DRF Systems

Engineering

Technical Support

Quality Assurance



8.2.2.2.2.1 SOP Specific Conformance

The Modality Worklist AE provides standard conformance to the DICOM Verification Service Class as a SCU.

The status of a C-ECHO request message is displayed (SUCCESS or FAIL).

Extended negotiation is not supported.

8.2.2.3 Association acceptance policy

The Modality Worklist AE never accepts associations.

Extended negotiation is not supported.

8.3 Network Communication Profiles

8.3.1 Supported Communication Stacks

The NEXUS system provides DICOM V3.0 TCP/IP Network Communication Support as defined in Part 8 of the DICOM Standard (PS 3.8).

8.3.2 OSI Stack

No OSI Stack communications are provided.

8.3.3 TCP/IP Stack

The NEXUS system supports the TCP/IP stack.

8.3.3.2 Physical media support

The NEXUS system is indifferent to the physical medium over which TCP/IP executes.

8.3.4 Point-to-Point Stack

No Point-to-Point Stack communications are provided.

8.4 Extensions/Specializations/Privatizations

The Storage AEs do not support any private attributes.

8.5 Configuration

The NEXUS system obtains its configuration information for SQL Server 2008 configuration database.

8.5.1 AE title/presentation address mapping

The presentation address mapping is defined in the configuration database. The destination AE title, host name, listen port and service list for each remote AE that the NEXUS system can connect to are defined in this database. The mapping of the hostname to an IP address is defined in the 'hosts' file.

DICOM 3.0 Conformance Statement for Varex Nexus DRF Systems

Engineering

Technical Support

Quality Assurance



8.5.2 Configurable Parameters

The following parameters may be configured:

Local AE Titles

1. Station name
2. Remote AEs:
 - a. AE Title
 - b. Hostname
 - c. Port number
3. Timeouts
 - a. Storage Commit timeout

In the 'hosts' file:

1. IP Addresses of remote AEs

The local network address, netmask and gateway are configured via the standard Windows Network configuration utility.

8.6 Support of Extended Character Sets

The NEXUS system supports the ISO_IR 100 Character set.

DICOM 3.0 Conformance Statement for Varex Nexus DRF Systems	
Engineering	
Technical Support	
Quality Assurance	

ANNEX A – DICOM Data Elements Supported
MODULES COMMON TO XA,RF, DX and SR IODs

Patient Module		PS3.3 section C.7.1.1	
Attribute Name	Tag	Type	Description
Patient's name	0010,0010	2	Patient's full legal name
Patient ID	0010,0020	2	Primary hospital ID number or code for the patient
Patient's birth date	0010,0030	2	Birth date of patient
Patient's sex	0010,0040	2	Sex of patient

General Study Module		PS3.3 section C.7.2.1	
Attribute Name	Tag	Type	Description
Study Instance UID	0020,000D	1	Unique identifier for study
Study Date	0008,0020	2	Date the Study started
Study Time	0008,0030	2	Time the Study started
Referring Physician's name	0008,0090	2	Patient's referring physician
Study ID	0020,0010	2	User or equipment generated Study Identifier
Accession Number	0008,0050	2	A RIS generated study number

Patient Study Module		PS3.3 section C.7.2.2	
Attribute Name	Tag	Type	Description
Patient's Age	0010,1010	3	Age of the patient
Patient's Size	0010,1020	3	Height – only if received from worklist
Patient's Weight	0010,1030	3	Weight – only if received from worklist
Occupation	0010,2180	3	Occupation of the Patient.

General Series Module		PS3.3 section C.7.3.1	
Attribute Name	Tag	Type	Description
Modality	0008,0060	1	Type of equipment that acquired image data
Series instance UID	0020,000E	1	Unique identifier of the Series
Series number	0020,0011	2	A number that identifies this Series
Laterality	0020,0060	2C	Laterality of (paired) body part examined
Series Date	0008,0021	3	Date the Series started
Series Time	0008,0031	3	Time the Series started
Performing physician's name	0008,1050	3	Name of physician administering the Series
Protocol Name	0018,1030	3	User defined description of conditions under which Series was performed
Series Description	0008,103E	3	User defined description of Series
Operator's Name	0008,1070	3	Technologist(s) supporting the Series
Body Part Examined	0018,0015	3	Text description of the part of the body examined
Patient Position	0018,5100	3	Patient position descriptor relative to the Equipment
Requested Procedure ID	0040,1001	3	ID of the Requested Procedure in the Imaging Service Request
Scheduled Procedure Step ID	0040,0009	3	ID of the Scheduled Procedure Step

DICOM 3.0 Conformance Statement for Varex Nexus DRF Systems

Engineering
 Technical Support
 Quality Assurance

General Series Module		PS3.3 section C.7.3.1	
Attribute Name	Tag	Type	Description
Performed Procedure Step ID	0040,0253	3	ID of that part of a Procedure that has been carried out within this step

General Equipment Module		PS3.3 section C.7.5.1	
Attribute Name	Tag	Type	Description
Manufacturer	0008,0070	2	Manufacturer of equipment that produced images
Institution name	0008,0080	3	Institution where equipment that produced images is located
Institution Address	0008,0081	3	Mailing address of the institution where the equipment is located that produced the digital images
Station name	0008,1010	3	User defined name identifying the machine that produced the images
Manufacturer's model name	0008,1090	3	Manufacturer's model number of the equipment that produced the images
Device Serial Number	0018,1000	3	Manufacturer's serial number of the equipment that produced the digital images
Software version	0018,1020	3	Manufacturer's designation of software version of equipment that produced images

General Image Module		PS3.3 section C.7.6.1	
Attribute Name	Tag	Type	Description
Image (instance) number	0020,0013	2	A number that identifies the image
Patient Orientation	0020,0020	2C	Patient direction of the rows and columns of the image
Image (content) date	0008,0023	2C	Date the image pixel data creation started
Image (content) time	0008,0033	2C	Time the image pixel data creation started
Image type	0008,0008	3	See IOD specific Image Module
Acquisition Number	0020,0012	3	A number identifying the single continuous gathering of data over a period of time which resulted in this image
Acquisition Date	0008,0022	3	The date the acquisition of data that resulted in this image started
Acquisition Time	0008,0032	3	The time the acquisition of data that resulted in this image started
Images in Acquisition	0020,1002	3	Number of images that resulted from this acquisition of data
Image comments	0020,4000	3	User defined comments about image
Lossy Image Compression	0028,2110	3	Specifies whether an image has undergone lossy compression

DICOM 3.0 Conformance Statement for Varex Nexus DRF Systems



Engineering
 Technical Support
 Quality Assurance

Attribute Derivation Description	0008,2111	3	Only sent when image was sent compressed, Note: Only sent when image was sent compressed using transfer syntax 1.2.840.10008.1.2.4.70
Source Image Sequence	0008,2112	3	The set of Image SOP Class/Instance pairs of the images that were used to derive this image - only sent for derived image
>Instance Number	0020,0013	1	A number that identifies the SOP Instance
>Content Label	0070,0080	1	A label that is used to identify this SOP Instance - Series and Image number
>Content Description	0070,0081	2	A description of the content of the SOP Instance – Exam Name
>Content Creator's Name	0070,0084	2	Name of operator (such as a technologist or physician) creating the content of the SOP Instance – Tech Initials if enabled, otherwise blank
>Referenced Frame Number	0008,1160	1C	Identifies the frame numbers within the Referenced SOP Instance to which the reference applies. The first frame shall be denoted as frame number 1. Note This Attribute may be multi-valued. Required if the Referenced SOP Instance is a multi-frame image

Image Pixel Module		PS3.3 section C.7.6.3	
Attribute Name	Tag	Type	Description
Samples per pixel	0028,0002	1	Number of samples (planes) in this image (1)
Photometric interpretation	0028,0004	1	Specifies the intended interpretation of the pixel data (MONOCHROME2)
Rows	0028,0010	1	Number of rows in image (512 or 1024)
Columns	0028,0011	1	Number of columns in image (512 or 1024)
Bits allocated	0028,0100	1	See IOD Image Module
Bits stored	0028,0101	1	See IOD Image Module
High bit	0028,0102	1	See IOD Image Module
Pixel representation	0028,0103	1	See IOD Image Module
Pixel data	7FE0,0010	1	Data stream of pixel samples which comprise the image

Modality LUT Module (Optional)		PS3.3 section C.11.1	
Attribute Name	Tag	Type	Description
Modality LUT Sequence	0028,3000	1C	Sequence of Modality LUTs (Not present if Rescale Intercept (0028,1052) is present)
> LUT Descriptor	0028,3002	1C	Format of LUT Data in Sequence
> LUT Explanation	0028,3003	3	Free Form Text
> LUT Type	0028,3004	1C	Specifies output values of this Modality LUT
> LUT Data	0028,3006	1C	LUT Data (Mapping of pixel value to pixel intensity)

DICOM 3.0 Conformance Statement for Varex Nexus DRF Systems

Engineering
 Technical Support
 Quality Assurance

Rescale Intercept	0028,1052	1C	Required if Modality LUT sequence is not present.
Rescale Slope	0028,1053	1C	Required if Rescale Intercept is present.
Rescale Type	0028,1054	1C	Required if Rescale Intercept is present.

VOI LUT Module (Optional)		PS3.3 section C.11.2	
Attribute Name	Tag	Type	Description
Window center	0028,1050	3	Window center for display. (512)
Window width	0028,1051	1C	Window width for display. Required if Window center (0028,1050) is sent. (1024)
VOI LUT Sequence	0028,3010	3	Sequence of VOI LUT
> LUT Descriptor	0028,3002	1C	Format of LUT Data in Sequence
> LUT Explanation	0028,3003	3	Free Form Text
> LUT Data	0028,3006	1C	LUT Data (Mapping of pixel value to pixel intensity)

MODULES COMMON TO XA and RF IODs

Contrast/Bolus Module (Conditional)		PS3.3 section C.7.6.4	
Required if contrast media used in this image			
Attribute Name	Tag	Type	Description
Contrast/Bolus agent	0018,0010	2	Contrast or bolus agent

Multi-Frame Module (Conditional)		PS3.3 section C.7.6.6	
Required if pixel data is Multi-Frame Cine data			
Attribute Name	Tag	Type	Description
Number of frames	0028,0008	1	Number of frames in a Multi-frame image
Frame increment pointer	0028,0009	1	Contains the Data Element Tag of the attribute which is used as the frame increment in Multi-frame pixel data.

Mask Module (Conditional)		PS3.3 section C.7.6.10	
Required if image may be subtracted			
Attribute Name	Tag	Type	Description
Mask Subtraction Sequence	0028,6100	1	Defines a sequence which describes mask subtraction operations for a multi-frame image.
>Mask Operation	0028,6101	1	Identify the type of mask operation to be performed (“AVG SUB”).
>Mask Frame Numbers	0028,6110	1C	Specifies the frame numbers of the pixel data used to generate the mask.

DICOM 3.0 Conformance Statement for Varex Nexus DRF Systems



Engineering
 Technical Support
 Quality Assurance

Recommended Viewing Mode	0028,1090	2	Specifies recommended viewing protocols (“SUB”)
--------------------------	-----------	---	---

X-Ray Image Module			PS3.3 section C.8.7.1
Attribute Name	Tag	Type	Description
Frame increment pointer	0028,0009	1C	Required if Multi-frame image. Contains Data Element Tag of the attribute which is used as the Frame increment in Multi-frame image pixel data
Image type	0008,0008	1	Image identification characteristics
Pixel intensity relationship	0028,1040	1	The relationship between the pixel sample values and the X-Ray beam intensity.
Samples per pixel	0028,0002	1	Number of samples (planes) in the image (1)
Photometric interpretation	0028,0004	1	Specifies the intended interpretation of the pixel data (MONOCHROME2)
Bits allocated	0028,0100	1	Number of bits allocated for each pixel sample (8 or 16)
Bits stored	0028,0101	1	Number of bits stored for each pixel sample (8 or 10)
High bit	0028,0102	1	Most significant bit for pixel sample data (7 or 9)
Pixel representation	0028,0103	1	Data representation of the pixel samples (0)

X-Ray Acquisition Module			PS3.3 section C.8.7.2
Attribute Name	Tag	Type	Description
KVP	0018,0060	2	Peak kilo voltage output of the X-Ray generator used
Tube Current	0018,1151	2C	X-Ray Tube Current in mA
Exposure	0018,1152	2C	The product of exposure time and X-Ray tube current expressed in mAs. Required if either Exposure Time (0018,1150) or X-Ray Tube Current (0018,1151) are not present.
Radiation setting	0018,1155	1	Identify the general level of X-Ray dose exposure
Intensifier Size	0018,1162	3	Diameter of X-ray intensifier in mm

Display Shutter Module (Optional)			PS3.3 section C.7.6.11
Attribute Name	Tag	Type	Description
Shutter shape	0018,1600	1	Shape of the shutter defined for display (CIRCULAR)
Center of circular shutter	0018,1610	1C	Required if shutter shape is CIRCULAR
Radius of circular shutter	0018,1612	1C	Required if shutter shape is CIRCULAR

X-Ray Collimator Module (Optional)			PS3.3 section C.8.7.3
Attribute Name	Tag	Type	Description
Collimator shape	0018,1700	1	Shape of collimator (RECTANGULAR or POLYGONAL)
Collimator left vertical edge	0018,1702	1C	Required if collimator shape is RECTANGULAR

DICOM 3.0 Conformance Statement for Varex Nexus DRF Systems



Engineering
 Technical Support
 Quality Assurance

Collimator right vertical edge	0018,1704	1C	Required if collimator shape is RECTANGULAR
Collimator upper horizontal edge	0018,1706	1C	Required if collimator shape is RECTANGULAR
Collimator lower horizontal edge	0018,1708	1C	Required if collimator shape is RECTANGULAR
Vertices of polygonal shutter	0018,1720	1C	Required if collimator shape is POLYGONAL

X-Ray Acquisition Dose Module			PS3.3 section C.8.7.8
Attribute Name	Tag	Type	Description
Exposure Index	0018,1411	3	Measure of the detector response to radiation in the relevant image region of an image acquired with a digital x-ray imaging system as defined in IEC 62494-1. Notes: 1. A string rather than binary Value Representation is used for this Attribute, in order to allow the sender to control the precision of the value as suggested in the report of AAPM Task Group 116. 2. This index value is scaled
Target Exposure Index	0018,1412	3	The target value used to calculate the Deviation Index (0018,1413) as defined in IEC 62494-1.
Deviation Index	0018,1413	3	A scaled representation of the difference of the Exposure Index compared to the Target Exposure Index as defined in IEC 62494-1 and the report of AAPM TG 116.

X-Ray XA IOD

X-Ray Table Module (Conditional)			PS3.3 section C.8.7.4
Required if image is created with table motion			
Attribute Name	Tag	Type	Description
Table motion	0018,1134	2	Is table moving or not

XA Positioner Module			PS3.3 section C.8.7.7
Attribute Name	Tag	Type	Description
Distance Source to Detector	0018,1110	3	Distance in mm from source to isocenter
Distance Source to Patient	0018,1111	3	Distance in mm from source to detector center
Positioner motion	0018,1500	2C	Used to describe activity of imaging device

DICOM 3.0 Conformance Statement for Varex Nexus DRF Systems	
Engineering	
Technical Support	
Quality Assurance	

Positioner primary angle	0018,1510	2	Position of the X-Ray image intensifier about the patient from the RAO to LAO direction
Positioner secondary angle	0018,1511	2	Position of the X-Ray image intensifier about the patient from the CAU to CRA direction

SOP Common Module		PS3.3 section C.12.1
Attribute Name	Tag	Description
SOP class UID	0008,0016	Uniquely identifies the SOP class X-Ray Angiographic Image Storage "1.2.840.10008.5.1.4.1.1.12.1"
SOP instance UID	0008,0018	Uniquely identifies the SOP instance

X-Ray RF IOD

SOP Common Module		PS3.3 section C.12.1
Attribute Name	Tag	Description
SOP class UID	0008,0016	Uniquely identifies the SOP class X-Ray Radiofluoroscopic Image Storage "1.2.840.10008.5.1.4.1.1.12.2"
SOP instance UID	0008,0018	Uniquely identifies the SOP instance

X-Ray DX IOD

DX SERIES MODULE ATTRIBUTES PS3.3 section C.8-68			
Attribute Name	Tag	Type	Description
Modality	0008,0060	1	Type of equipment that originally acquired the data used to create the images in this Series. Enumerated Values: DX PX IO MG See section C.7.3.1.1.1 for further explanation.
Presentation Intent Type	0008,0068	1	Identifies the intent of the images that are contained within this Series. Enumerated Values: FOR PRESENTATION FOR PROCESSING

DICOM 3.0 Conformance Statement for Varex Nexus DRF Systems

Engineering

Technical Support

Quality Assurance

DX ANATOMY IMAGED MODULE ATTRIBUTES PS3.3 section C.8-69

Attribute Name	Tag	Type	Description
Image Laterality	0020,0062	1	Enumerated Values: R = right L = left U = unpaired B = both left and right
Anatomic Region Sequence	0008,2218	2	Sequence that identifies the anatomic region of interest in this Instance (i.e., external anatomy, surface anatomy, or general region of the body). Zero or one Item shall be included in this Sequence. Nexus always sends empty

DICOM 3.0 Conformance Statement for Varex Nexus DRF Systems



Engineering
 Technical Support
 Quality Assurance

DX IMAGE MODULE ATTRIBUTES PS3.3 section C.8-70			
Attribute Name	Tag	Type	Description
Image Type	(0008,0008)	1	Image identification characteristics. See C.8.11.3.1.1 for specialization.
Samples per Pixel	(0028,0002)	1	Number of samples in this image. Shall have an Enumerated Value of 1.
Photometric Interpretation	(0028,0004)	1	Specifies the intended interpretation of the pixel data. Enumerated Values: MONOCHROME1 MONOCHROME2
Bits Allocated	(0028,0100)	1	Number of bits allocated for each pixel sample. Enumerated Values: 8, 16
Bits Stored	(0028,0101)	1	Number of bits stored for each pixel sample. Enumerated Values: 6 to 16
High Bit	(0028,0102)	1	Most significant bit for pixel sample data. Shall have an Enumerated Value of one less than the value in Bit Stored (0028,0101).
Pixel Representation	(0028,0103)	1	Data representation of the pixel samples. Shall have the Enumerated Value: 0000H = Unsigned Integer.
Pixel Intensity Relationship	(0028,1040)	1	The relationship between the Pixel sample values and the X-Ray beam intensity. Enumerated Values: LIN = Linearly proportional to X-Ray beam intensity LOG = Logarithmically proportional to X-Ray beam intensity See C.8.11.3.1.2 for further explanation.
Image Type	(0008,0008)	1	Image identification characteristics. See C.8.11.3.1.1 for specialization.
Samples per Pixel	(0028,0002)	1	Number of samples in this image. Shall have an Enumerated Value of 1.
Photometric Interpretation	(0028,0004)	1	Specifies the intended interpretation of the pixel data. Enumerated Values: MONOCHROME1 MONOCHROME2
Bits Allocated	(0028,0100)	1	Number of bits allocated for each pixel sample.

DICOM 3.0 Conformance Statement for Varex Nexus DRF Systems



Engineering
 Technical Support
 Quality Assurance

			Enumerated Values: 8, 16
Bits Stored	(0028,0101)	1	Number of bits stored for each pixel sample. Enumerated Values: 6 to 16
High Bit	(0028,0102)	1	Most significant bit for pixel sample data. Shall have an Enumerated Value of one less than the value in Bit Stored (0028,0101).
Pixel Representation	(0028,0103)	1	Data representation of the pixel samples. Shall have the Enumerated Value: 0000H = Unsigned Integer.
Pixel Intensity Relationship	(0028,1040)	1	The relationship between the Pixel sample values and the X-Ray beam intensity. Enumerated Values: LIN = Linearly proportional to X-Ray beam intensity LOG = Logarithmically proportional to X-Ray beam intensity See C.8.11.3.1.2 for further explanation.
Pixel Intensity Relationship Sign	(0028,1041)	1	The sign of the relationship between the Pixel sample values stored in Pixel Data (7FE0,0010) and the X-Ray beam intensity. Enumerated Values; 1 = Lower pixel values correspond to less X-Ray beam intensity -1 = Higher pixel values correspond to less X-Ray beam intensity See C.8.11.3.1.2 for further explanation.
Rescale Intercept	(0028,1052)	1	The value b in the relationship between stored values (SV) in Pixel Data (7FE0,0010) and the output units specified in Rescale Type (0028,1054). Output units = m*SV + b. Enumerated Value: 0 See C.8.11.3.1.2 for further explanation.

DICOM 3.0 Conformance Statement for Varex Nexus DRF Systems



Engineering
 Technical Support
 Quality Assurance

Rescale Slope	(0028,1053)	1	m in the equation specified by Rescale Intercept (0028,1052). Enumerated Value: 1 See C.8.11.3.1.2 for further explanation.
Rescale Type	(0028,1054)	1	Specifies the output units of Rescale Slope (0028,1053) and Rescale Intercept (0028,1052). Enumerated Value: US = Unspecified See C.8.11.3.1.2 for further explanation.
Presentation LUT Shape	(2050,0020)	1	Specifies an identity transformation for the Presentation LUT, other than to account for the value of Photometric Interpretation (0028,0004), such that the output of all grayscale transformations defined in the IOD containing this Module are defined to be P-Values. Enumerated Values: IDENTITY – output is in P-Values – shall be used if Photometric Interpretation (0028,0004) is MONOCHROME2. INVERSE – output after inversion is in P-Values – shall be used if Photometric Interpretation (0028,0004) is MONOCHROME1. See C.8.11.3.1.2 for further explanation.
Lossy Image Compression	(0028,2110)	1	Specifies whether an Image has undergone lossy compression. Enumerated Values: 00 = Image has NOT been subjected to lossy compression. 01 = Image has been subjected to lossy compression. See C.7.6.1.1.5 for further explanation.
Lossy Image Compression Ratio	(0028,2112)	1C	See C.7.6.1.1.5 for further explanation. Required if Lossy Compression has been performed on the Image.

DICOM 3.0 Conformance Statement for Varex Nexus DRF Systems



Engineering
 Technical Support
 Quality Assurance

Derivation Description	(0008,2111)	3	A text description of how this image was derived. See C.8.11.3.1.4 for further explanation.
Acquisition Device Processing Description	(0018,1400)	3	Indicates any visual processing performed on the images prior to exchange. See C.8.11.3.1.3 for further explanation.
Acquisition Device Processing Code	(0018,1401)	3	Code representing the device-specific processing associated with the image (e.g. Organ Filtering code) Note: This Code is manufacturer specific but provides useful annotation information to the knowledgeable observer.
Patient Orientation	(0020,0020)	1C	Patient direction of the rows and columns of the image. See C.7.6.1.1.1 for further explanation. Required if View Code Sequence (0054,0220) is not present or is present with an Item value other than (G-8300, SRT, "tissue specimen") or (G-8310, SRT, "tissue specimen from breast"). May be present otherwise.
Calibration Image	(0050,0004)	3	Indicates whether a reference object (phantom) of known size is present in the image and was used for calibration. Enumerated Values: YES NO Device is identified using the Device module. See C.7.6.12 for further explanation.
Burned In Annotation	(0028,0301)	1	Indicates whether or not image contains sufficient burned in annotation to identify the patient and date the image was acquired. Enumerated Values: YES

DICOM 3.0 Conformance Statement for Varex Nexus DRF Systems



Engineering
 Technical Support
 Quality Assurance

			NO
Window Center	(0028,1050)	1C	Defines a Window Center for display. See C.8.11.3.1.5 for further explanation. Required if Presentation Intent Type (0008,0068) is FOR PRESENTATION and VOI LUT Sequence (0028,3010) is not present. May also be present if VOI LUT Sequence (0028,3010) is present.
Window Width	(0028,1051)	1C	Window Width for display. See C.8.11.3.1.5 for further explanation. Required if Window Center (0028,1050) is sent.
Window Center & Width Explanation	(0028,1055)	3	Free form explanation of the meaning of the Window Center and Width. Multiple values correspond to multiple Window Center and Width values.

DX DETECTOR MODULE ATTRIBUTES PS3.3 section C.8-71

Attribute Name	Tag	Type	Description
Imager Pixel Spacing	(0018,1164)	1	Physical distance measured at the front plane of the detector housing between the center of each image pixel specified by a numeric pair - row spacing value (delimiter) column spacing value in mm. See 10.7.1.3 for further explanation of the value order. The value of this attribute shall never be adjusted to account for correction for the effect of geometric magnification or calibration against an object of known size; Pixel Spacing (0028,0030) is specified for that purpose.

DICOM 3.0 Conformance Statement for Varex Nexus DRF Systems

Engineering

Technical Support

Quality Assurance

X-Ray Radiation Dose SR IOD

SR DOCUMENT PATIENT MODULE ATTRIBUTES PS3.3 section C.7.1.1			
Attribute Name	Tag	Type	Description
Patient's Name	(0010,0010)	2	Patient's full name
Patient ID	(0010,0020)	2	Primary identifier for the patient
Patient's Birth Date	(0010,0030)	2	Birth date of the patient

SR DOCUMENT GENERAL STUDY MODULE ATTRIBUTES PS3.3 section C.7.2.1			
Attribute Name	Tag	Type	Description
Study Instance UID	(0020,000D)	1	Unique identifier for the Study.
Study Date	(0008,0020)	2	Date the Study started.
Study Time	(0008,0030)	2	Time the Study started.
Referring Physician's Name	(0008,0090)	2	Name of the patient's referring physician
Study ID	(0020,0010)	2	User or equipment generated Study identifier.
Accession Number	(0008,0050)	2	A RIS generated number that identifies the order for the Study.
Study Description	(0008,1030)	3	Institution-generated description or classification of the Study (component) performed.

SR DOCUMENT PATIENT STUDY MODULE ATTRIBUTES PS3.3 section C.7.2.2			
Attribute Name	Tag	Type	Description
Patient's Size	(0010,1020)	3	Length or size of the Patient
Patient's Weight	(0010,1030)	3	Weight of the Patient

SR DOCUMENT GENERAL SERIES MODULE ATTRIBUTES PS3.3 section C.7.3.1			
Attribute Name	Tag	Type	Description
Modality	(0008,0060)	1	Type of equipment that originally acquired the data used to create the images in this Series. See Section C.7.3.1.1.1 for Defined Terms.
Series Instance UID	(0020,000E)	1	Unique identifier of the Series
Series Number	(0020,0011)	2	A number that identifies this Series
Performing Physician's Name	(0008,1050)	3	Name of the physician(s)

DICOM 3.0 Conformance Statement for Varex Nexus DRF Systems



Engineering
 Technical Support
 Quality Assurance

			administering the Series.
Protocol Name	(0018,1030)	3	Work Procedure Name
Operators' Name	(0008,1070)	3	Tech Initials

SR DOCUMENT SERIES MODULE ATTRIBUTES PS3.3 section C.17.1			
Attribute Name	Tag	Type	Description
Modality	(0008,0060)	1	Modality type. Enumerated Values: SR SR Document
Series Instance UID	(0020,000E)	1	Unique identifier of the Series. Note No SR-specific semantics are specified.
Series Number	(0020,0011)	1	A number that identifies the Series. Note No SR-specific semantics are specified. Note: Nexus DRF always sends 1
Referenced Performed Procedure Step Sequence	(0008,1111)	2	Uniquely identifies the Performed Procedure Step SOP Instance for which the Series is created. Zero or one Item shall be included in this Sequence. Note 1. The Performed Procedure Step referred to by this Attribute is the Step during which this Document is generated. 2. If this Document is generated during the same Performed Procedure Step as the evidence in the current interpretation procedure, this Attribute may contain reference to that Performed Procedure Step. 3. This Attribute is not used to convey reference to the evidence in the current interpretation procedure. See Current Requested Procedure Evidence Sequence (0040,A375).

DICOM 3.0 Conformance Statement for Varex Nexus DRF Systems



Engineering
 Technical Support
 Quality Assurance

			<p>4. This Sequence may be zero length if the Performed Procedure Step is unknown.</p> <p>Note: Nexus DRF always sends NULL</p>
--	--	--	---

SR DOCUMENT GENERAL EQUIPMENT MODULE ATTRIBUTES PS3.3 section C.7.5.1			
Attribute Name	Tag	Type	Description
Manufacturer	(0008,0070)	2	Manufacturer of the equipment that produced the composite instances.
Institution Name	(0008,0080)	3	Institution where the equipment that produced the composite instances is located.
Manufacturer's Model Name	(0008,1090)	3	Manufacturer's model name of the equipment that produced the composite instances.
Device Serial Number	(0018,1000)	3	Manufacturer's serial number of the equipment that produced the composite instances
Software Versions	(0018,1020)	3	Manufacturer's designation of software version of the equipment that produced the composite instances. See Section C.7.5.1.1.3.

SR DOCUMENT GENERAL MODULE ATTRIBUTES PS3.3 section C.17.2			
Attribute Name	Tag	Type	Description
Instance Number	(0020,0013)	1	<p>A number that identifies the SR Document.</p> <p>Note: Nexus DRF always sends 1</p>
Completion Flag	(0040,A491)	1	<p>The estimated degree of completeness of this SR Document. See Section C.17.2.7. Enumerated Values: PARTIAL Partial content. COMPLETE Complete content.</p> <p>Note: Nexus DRF always sends Complete</p>
Verification Flag	(0040,A493)	1	<p>Indicates whether this SR Document is Verified. Enumerated Values: UNVERIFIED Not attested to.</p>

DICOM 3.0 Conformance Statement for Varex Nexus DRF Systems



Engineering
 Technical Support
 Quality Assurance

			<p>VERIFIED Attested to by a Verifying Observer Name (0040,A075) who is accountable for its content. A value of "VERIFIED" shall be used only when the value of Completion Flag (0040,A491) is "COMPLETE".</p> <p>Note The intent of this specification is that the "prevailing final version" of an SR Document is the version having the most recent Verification DateTime (0040,A030), Verification Flag (0040,A493) of VERIFIED and Preliminary Flag (0040,A496) of FINAL.</p> <p>Note: Nexus DRF always sends Unverified</p>
Content Date	(0008,0023)	1	The date the document content creation started.
Content Time	(0008,0033)	1	The time the document content creation started.
Performed Procedure Code Sequence	(0040,A372)	2	<p>A Sequence that conveys the codes of the performed procedures pertaining to this SOP Instance. Zero or more Items shall be included in this Sequence.</p> <p>Note: Nexus DRF always sends this as Null</p>
Reason for the Requested Procedure	(0040,1002)	3	<p>Reason for requesting this procedure.</p> <p>Note: Nexus DRF only sends this if it is received from the WL</p>

SR Templates

TID 10001 Projection X-Ray Radiation Dose								
	NL	Rel with Parent	VT	Concept Name	VM	Req Type	Condition	Value Set Constraint
1			CONTAINER	EV(113701, DCM, "X-Ray Radiation Dose Report")	1	M		

DICOM 3.0 Conformance Statement for Varex Nexus DRF Systems



Engineering
 Technical Support
 Quality Assurance

2	>	HAS CONCEPT MOD	CODE	EV(121058, DCM, "Procedure reported")	1	M		113704, DCM, "Projection X-Ray"
3	>>	HAS CONCEPT MOD	CODE	EV(363703001, SCT, "Has Intent")	1	M		R-408C3, SRT, "Diagnostic Intent"
4	>	CONTAINS	CODE	EV (122142, DCM, "Acquisition Device Type")	1	U		113957, DCM, "Fluoroscopy-Guided Projection Radiography System"
5	>		INCLUDE	DTID 1002 "Observer Context"	1-n	M		
6	>	HAS OBS CONTEXT	CODE	EV (113705, DCM, "Scope of Accumulation")	1	M		113014, DCM, "Study"
7	>>	HAS PROPERTIES	UIDREF	DCID 10001 "UID Types"	1	M		110180, DCM, "Study Instance UID"
8	>	CONTAINS	CODE	EV (113945, DCM, "X-Ray Detector Data Available")	1	U		R-00339, SRT, "No"
9	>	CONTAINS	CODE	EV (113943, DCM, "X-Ray Source Data Available")	1	U		R-0038D, SRT, "Yes"
10	>	CONTAINS	CODE	EV (113944, DCM, "X-Ray Mechanical Data Available")	1	U		R-00339, SRT, "No"
11	>	CONTAINS	INCLUDE	DTID 10002 "Accumulated X-Ray Dose"	1	MC	IFF Single Plane system	
14	>	CONTAINS	INCLUDE	DTID 10003 "Irradiation Event"	1-n	MC	IF any of the values of TID (10001) Row	

DICOM 3.0 Conformance Statement for Varex Nexus DRF Systems



Engineering
 Technical Support
 Quality Assurance

				X-Ray Data"			18 are not (113858, DCM, "MPPS Content"), (113866, DCM, "Copied From Image Attributes") or (113867, DCM, "Computed From Image Attributes")	
18	>	CONTAINS	CODE	EV (113854, DCM, "Source of Dose Information")	1-n	M		113856, DCM, "Automated Data Collection"

TID 1002 Observer Context

	NL	Rel with Parent	VT	Concept Name	VM	Req Type	Condition	Value We Set
1		HAS OBS CONTEXT	CODE	EV (121005, DCM, "Observer Type")	1	MC	IF Observer type is device	121007, DCM, "Device"
3		HAS OBS CONTEXT	INCLUDE	DTID 1004 "Device Observer Identifying Attributes"	1	MC	IFF Row 1 value = (121007, DCM, "Device")	

TID 1004 Observer Identifying Attributes

	NL	Rel with Parent	VT	Concept Name	VM	Req Type	Condition	Value We Set
1			UIDREF	EV (121012, DCM, "Device Observer UID")	1	M		Dicom Base UID + System SN
2			TEXT	EV (121013, DCM, "Device Observer Name")	1	U		Institution Name
				EV (121014, DCM,				System

DICOM 3.0 Conformance Statement for Varex Nexus DRF Systems



Engineering
 Technical Support
 Quality Assurance

3			TEXT	"Device Observer Manufacturer")	1	U		Manufacturer
4			TEXT	EV (121015, DCM, "Device Observer Model Name")	1	U		System Model Name
5			TEXT	EV (121016, DCM, "Device Observer Serial Number")	1	U		System SN

TID 10002 Accumulated X-Ray Dose

	NL	Rel with Parent	VT	Concept Name	VM	Req Type	Condition	Value We Set
1			CONTAINER	EV (113702, DCM, "Accumulated X-Ray Dose Data")	1	M		
2	>	HAS CONCEPT MOD	CODE	EV (113764, DCM, "Acquisition Plane")	1	M		113622, DCM, "Single Plane"
10	>	CONTAINS	INCLUDE	DTID 10004 "Accumulated Fluoroscopy and Acquisition Projection X-Ray Dose"	1	MC	IFF TID 10001 Row 4 = (113957, DCM, "Fluoroscopy-Guided Projection Radiography System") or TID 10001 Row 2 = (113704, DCM, "Projection X-Ray") and TID 10001 Row 4 is absent)	
12	>	CONTAINS	INCLUDE	DTID 10007 "Accumulated Total Projection Radiography Dose"	1	MC	IFF TID 10001 Row 4 = (113958, DCM, "Integrated Projection Radiography System") or TID (10001) Row 4 = (113957, DCM, "Fluoroscopy-Guided Projection Radiography System") or TID (10001) Row 2 = (113704, DCM, "Projection X-	

DICOM 3.0 Conformance Statement for Varex Nexus DRF Systems



Engineering
 Technical Support
 Quality Assurance

							Ray") and TID (10001) Row 4 is absent)	
--	--	--	--	--	--	--	--	--

TID 10004 Accumulated Fluoroscopy and Acquisition Projection X-Ray Dose

	NL	Rel with Parent	VT	Concept Name	VM	Req Type	Condition	Value We Set
1			NUM	EV (113726, DCM, "Fluoro Dose Area Product Total")	1	MC	IFF TID 10003 Row 7 value = (P5-06000, SRT, "Fluoroscopy") for at least one irradiation event	("Gy.m2", "UCUM", "Gray meters-squared")
2			NUM	EV (113728, DCM, "Fluoro Dose (RP) Total")	1	MC	IFF TID 10003 Row 7 value = (P5-06000, SRT, "Fluoroscopy") for at least one irradiation event AND any of the values of TID (10001) Row 18 are not (113858, DCM, "MPPS Content").	("Gy", "UCUM", "Grays")
3			NUM	EV (113730, DCM, "Total Fluoro Time")	1	MC	IFF TID 10003 Row 7 value = (P5-06000, SRT, "Fluoroscopy") for at least one irradiation event.	UNITS = EV (s, UCUM, "seconds")
4			NUM	EV (113727, DCM, "Acquisition Dose Area Product Total")	1	MC	IF any of the values of TID (10001) Row 18 are not (113858, DCM, "MPPS Content").	("Gy.m2", "UCUM", "Gray meters-squared")
5			NUM	EV (113729, DCM, "Acquisition Dose (RP) Total")	1	MC	IF any of the values of TID (10001) Row 18 are not (113858, DCM, "MPPS Content").	("Gy", "UCUM", "Grays")
6			NUM	EV (113855, DCM, "Total Acquisition Time")	1	MC	IF any of the values of TID (10001) Row 18 are not (113858, DCM, "MPPS Content").	UNITS = EV (s, UCUM, "seconds")

TID 10007 Accumulated Total Projection Radiography Dose

	NL	Rel with Parent	VT	Concept Name	VM	Req Type	Condition	Value We Set
				EV (113722,				UNITS = EV

DICOM 3.0 Conformance Statement for Varex Nexus DRF Systems



Engineering
 Technical Support
 Quality Assurance

1			NUM	DCM, "Dose Area Product Total")	1	M		("Gy.m2", "UCUM", "Gray meters-squared")
2			NUM	EV (113725, DCM, "Dose (RP) Total")	1	MC	IF TID 10001 Row 4 = (113958, DCM, "Integrated Projection Radiography System") or any of the values of TID (10001) Row 18 are not (113858, DCM, "MPPS Content").	UNITS = EV ("Gy", "UCUM", "Grays")
4			NUM	EV (113731, DCM, "Total Number of Radiographic Frames")	1	U		UNITS = EV (frames, UCUM, "frames")
5			CODE	EV (113780, DCM, "Reference Point Definition")	1	MC	IF any of (113725, DCM, "Dose (RP) Total"), (113728, DCM, "Fluoro Dose (RP) Total") or (113729, DCM, "Acquisition Dose (RP) Total") are present, and Row 6 is not present.	113860, DCM, "15cm from Isocenter toward Source"

TID 10003 Irradiation Event X-Ray Data

	NL	Rel with Parent	VT	Concept Name	VM	Req Type	Condition	Value We Set
1			CONTAINER	EV (113706, DCM, "Irradiation Event X-Ray Data")	1	M		
2	>	HAS CONCEPT MOD	CODE	EV (113764, DCM, "Acquisition Plane")	1	M		DCM, 113622, Single Plane Note: Report may rearrange or not show all the data listed
3	>	CONTAINS	DATETIME	DT (111526, DCM, "DateTime Started")	1	M		
7	>	CONTAINS	CODE	EV (113721,	1	M		SRT, P5-06000,

DICOM 3.0 Conformance Statement for Varex Nexus DRF Systems



Engineering
 Technical Support
 Quality Assurance

				DCM, "Irradiation Event Type")				Fluoroscopy or DCM, 113611, Stationary Acquisition Note: Report may rearrange or not show all the data listed
8	>	CONTAINS	TEXT	EV (125203, DCM, "Acquisition Protocol")	1	U		Region/Exam/Position
9	>	CONTAINS	CODE	EV (T-D0005, SRT, "Anatomical structure")	1	U		SRT, Value, Meaning from associated exam
10	>>	HAS CONCEPT MOD	CODE	EV (G-C171, SRT, "Laterality")	1	UC	If anatomy isbi-lateral	SRT, G-A100, Right or SRT, G-A101, Left or SRT, G-A102, Bilateral or SRT, G-A103, Unilateral Note: Report may rearrange or not show all the data listed
17	>	CONTAINS	CODE	EV (123014, DCM, "Target Region")	1	M		SRT, Value, Meaning from Associated Exam Note: Report may rearrange or not show all the data

DICOM 3.0 Conformance Statement for Varex Nexus DRF Systems



Engineering
 Technical Support
 Quality Assurance

								listed
18	>	CONTAINS	NUM	EV (122130, DCM, "Dose Area Product")	1	MC		UNITS = EV (Gy.m2, UCUM, "Gy.m2")
21	>	CONTAINS	NUM	EV (111636, DCM, "Entrance Exposure at RP")	1	MC		UNITS = EV (mGy, UCUM, "mGy")

TID 10003b Irradiation Event X-Ray Source Data

	NL	Rel with Parent	VT	Concept Name	VM	Req Type	Condition	Value We Set
1			NUM	EV (113738, DCM, "Dose (RP)")	1	MC	IF TID (10001) Row 2 = (113704, DCM, "Projection X-Ray") AND any of the values of TID (10001) Row 18 are not (113858, DCM, "MPPS Content")	UNITS = EV (Gy, UCUM, "Gy")
3			CODE	EV (113764, DCM, "Acquisition Plane")	1	MC	IF Row 1 is present and Row 2 is not present	DCM, 113860, 15cm from Isocenter toward Source
5			CODE	EV (113732, DCM, "Fluoro Mode")	1	UC	IFF TID (10003) Row 7 value = (P5-06000, SRT, "Fluoroscopy")	DCM, 113631, Pulsed
6			NUM	EV (113791, DCM, "Pulse Rate")	1	MC	IFF Row 5 value = (113631, DCM, "Pulsed")	UNITS = EV ({pulse}/s, UCUM, "pulse/s")
7			NUM	EV (113768, DCM, "Number of Pulses")	1	MC	IFF Row 5 is not present or Row 5 is present and equals (113631, DCM, "Pulsed")	UNITS = EV (1, UCUM, "no units")
10			NUM	EV (113742, DCM, "Irradiation")	1	U		UNITS = EV (s, UCUM,

DICOM 3.0 Conformance Statement for Varex Nexus DRF Systems



Engineering
 Technical Support
 Quality Assurance

				Duration")				"s")
11			NUM	EV (113733, DCM, "KVP")	1 - n	M		UNITS = EV (kV, UCUM, "kV")
12			NUM	EV (113734, DCM, "X-Ray Tube Current")	1- n	MC	IF Row 15 is not present	UNITS = EV (mA, UCUM, "mA")
14			NUM	EV (113824, DCM, "Exposure Time")	1	MC	IF Row 15 is not present	UNITS = EV (ms, UCUM, "ms")
15			NUM	EV (113736, DCM, "Exposure")	1-n	MC	IF Row 12 and 14 are not present	UNITS = EV (uA.s, UCUM, "uA.s")
18			CONTAINER	EV (113771, DCM, "X-Ray Filters"	1-n	U		
19	>	CONTAINS	CODE	EV (113772, DCM, "X-Ray Filter Type")	1	U		EV (113653, DCM, "Flat Filter") Or EV (113609, DCM, "No Filter")
20	>	CONTAINS	CODE	EV (113772, DCM, "X-Ray Filter Material")	1	U		EV (C-120F9, SRT, "Aluminum or Aluminum compound") Or EV (C-127F9, SRT, "Copper or Copper compound") Not sent if Filter Type is "No Filter"

DICOM 3.0 Conformance Statement for Varex Nexus DRF Systems



Engineering
 Technical Support
 Quality Assurance

21	>	CONTAINS	NUM	EV (113758, DCM, "X-Ray Filter Thickness Minimum")	1	U		UNITS = EV (mm, UCUM, "mm") Not sent if Filter Type is "No Filter"
22	>	CONTAINS	NUM	EV (113758, DCM, "X-Ray Filter Thickness Maximum")	1	U		UNITS = EV (mm, UCUM, "mm") Not sent if Filter Type is "No Filter"

Note: Filter data will be sent only if system receives the information

ANNEX B - Worklist AE Attributes

Table B.1: Type 1 Fields Requested From Provider

DICOM Tag	Description	Field Use
0040,0100	Scheduled Procedure Step Sequence	Sequence
0040,0001	Scheduled Station AE Title	Match/Return
0040,0002	Scheduled Procedure Step Start Date	Match
0040,0003	Scheduled Procedure Step Start Time	Return
0008,0060	Modality	Match
0040,0007	Scheduled Procedure Step Description	Return
0040,0009	Scheduled Procedure Step ID	Return
0040,1001	Requested Procedure ID	Return
0020,000D	Study Instance UID	Return
0010,0010	Patient Name	Match
0010,0020	Patient ID	Match
0040, 0008	Scheduled Protocol Code Sequence	Sequence
>0008, 0100	Code Value	Return
>0008,0102	Coding Scheme Designator	Return
>0008, 0104	Code Meaning	Return
0032,1064	Requested Procedure Code Sequence	Sequence
>0008,0100	Code Value	Return
>0008,0102	Coding Scheme Designator	Return
>0008,104	Code Meaning	Return

DICOM 3.0 Conformance Statement for Varex Nexus DRF Systems	
Engineering	
Technical Support	
Quality Assurance	

Table B.2: Type 2 and 3 Fields Requested From Provider

DICOM Tag	Description	Field Use
0010,0030	Patient's Birth Date	Return
0010,0040	Patient's Sex	Return
0010,1030	Patient's Weight	Return
0040,0006	Scheduled Performing Physician Name	Return
0008,0050	Accession Number	Match/Return
0032,1032	Requesting Physician	Return
0008,0090	Referring Physician	Return
0008,1110	Referenced Study Sequence	Sequence
>0008,1150	Referenced SOP Class UID	Return
>0008,1155	Referenced SOP Instance UID	Return
0040,1002	Reason for the Requested Procedure	Return

ANNEX C – MWM Attributes available for DICOM storage

Table C. 1 Common Attributes in Modality Worklist Management and DICOM storage

Attribute Name	Tag	Type	Description
Modality	0008,0060	1	Type of equipment that acquired image data (XA)
Study Instance UID	0020,000D	1	Unique Identifier for Study
Patient Name	0010,0010	2	Patient's full legal name
Patient ID	0010,0020	2	Primary hospital ID number or code for the patient
Patient's Birth Date	0010,0030	2	Birth date of the patient
Accession Number	0008,0050	2	A RIS generated study number
Referring Physician	0008,0090	2	Patient's referring Physician

Table C.2 MPSS Attributes

Attribute Name	Tag	Description
Performed Station AE Title	(0040,0241)	AE title of the modality on which the Performed Procedure Step was performed.

DICOM 3.0 Conformance Statement for Varex Nexus DRF Systems



Engineering
 Technical Support
 Quality Assurance

Performed Station Name	(0040,0242)	An institution defined name for the modality on which the Performed Procedure Step was performed.
Performed Location	(0040,0243)	Description of the location at which the Performed Procedure Step was performed.
Performed Procedure Step Start Date	(0040,0244)	Date on which the Performed Procedure Step started. Note: This value may be used to determine the earliest date to use as the Study Date (0008,0020) in composite instances and in updated Modality Scheduled Procedure Steps in order to allow Study level attributes to have consistent values if additional Procedure Steps are performed.
Performed Procedure Step Start Time	(0040,0245)	Time at which the Performed Procedure Step started. Note: This value may be used to determine the earliest time to use as the Study Time (0008,0030) in composite instances and in updated Modality Scheduled Procedure Steps in order to allow Study level attributes to have consistent values if additional Procedure Steps are performed.
Performed Procedure Step ID	(0040,0253)	User or equipment generated identifier of that part of a Procedure that has been carried out within this step
Performed Procedure Step End Date	(0040,0250)	Date on which the Performed Procedure Step ended.
Performed Procedure Step End Time	(0040,0251)	Time at which the Performed Procedure Step ended.
Performed Procedure Step Status	(0040,0252)	Contains the state of the Performed Procedure Step. Enumerated Values: IN PROGRESS = Started but not complete DISCONTINUED = Canceled or unsuccessfully terminated COMPLETED = Successfully completed
Performed Procedure Step Description	(0040,0254)	Institution-generated description or classification of the Procedure Step that was performed.

DICOM 3.0 Conformance Statement for Varex Nexus DRF Systems



Engineering
 Technical Support
 Quality Assurance

Comments on the Performed Procedure Step	(0040,0280)	User-defined comments on the Performed Procedure Step.
Performed Procedure Type Description	(0040,0255)	A description of the type of procedure performed.
Procedure Code Sequence	(0008,1032)	A sequence that conveys the (single) type of procedure performed. Only a single Item shall be included in this sequence.
Reason For Performed Procedure Code Sequence	(0040,1012)	Coded reason(s) for performing this procedure. Note: May differ from the values in Reason for the Requested Procedure (0040,100A) in Request Attribute Sequence (0040,0275), for example if what was performed differs from what was requested. One or more Items shall be included in this Sequence.
Performed Procedure Step Discontinuation Reason Code Sequence	(0040,0281)	The reason the Performed Procedure Step Status (0040,0252) was set to DISCONTINUED.

0.0 Revisions

Rev	Date	Initials	EC	Training Req'd (x)	Purpose
A	03/31/2014	SPW	1059704	--	<ul style="list-style-type: none"> New Release for NEXUS
B	11/09/2017	MCY	00134	--	<ul style="list-style-type: none"> Changed Varian to Varex
C	1/21/2020	SPW	0000217	--	<ul style="list-style-type: none"> Updated for Nexus DRF 3.2
D	1/25/2021	SPW	0002058	--	<ul style="list-style-type: none"> Updated for DICOM compression, removed Secondary Capture, and updated for DICOM Structure Dose Report, updated C.7.2.2