

Linatron[®]M6 & M6A

Modular High-energy X-Ray Source



X-Ray Head and RF Unit

The Linatron[®] M™ is a modular system. The control console, modulator, and RF unit are common to all model configurations. Only the X-ray head changes to match the application. The Linatron M is designed to fit mobile, gantry, and fixed installations.

1.0 Standard Equipment and Services

1.1 Control Console

The standard control console is a touch screen display system. Includes 2 key safety and remote interlock.

1.2 X-ray Head/RF Unit

1.3 Modulator/Power Distribution Cabinet/External Signal Interface.

1.4 Temperature Control Unit (TCU)

The TCU is used to keep the system components at a nominal 30°C (86°F).

1.5 Spare Parts Kits

- Compulsory
- Standard
- Extended

1.6 Interconnecting cables include with lengths up to 100 meters (330 ft.).

Interconnecting hoses included:

With lengths up to 91 meters (300 ft) for indoor application with lengths up to 45 meters (150 ft) for outdoor application.

1.7 Manuals

Operator Manuals are included in English.

1.8 Installation Supervision and Start-up Assistance

1.9 Varex's Standard Warranty

2.0 X-ray Beam Characteristics

2.1. Dose Rate - measured 1 meter from target in central axis of a 10-cm x 10-cm field. Listed in Gy/min-meter. (See Table 1)

2.2. Energy - measured with Half Value Layer (HVL) method in steel and listed in inches of steel as well as nominal energy in MV. (See Table 1)

2.3. Focal Spot Size - measured using Full Width Half Max method and does not exceed 2.0 mm.

2.4. Field Flatness - measured at 1 meter from target at $\pm 7.5^\circ$ off the central axis. Listed as percent of the central axis dose rate. See Table 1.

2.5. Field Size - field collimation is custom for each system. See Table 2 for options.

Linatron M6 & M6A

Modular High-energy X-Ray Source



- 2.6. Field Symmetry - beam asymmetry is measured at 1 meter from target and does not exceed 5% (for symmetric collimation options).
- 2.7. Leakage Radiation - measured along the horizontal plane at 1 meter from the beam centerline at angles > 60° outside of the primary beam. Listed as a fraction of the primary beam central axis dose rate; (excluding primary beam scatter). Leakage radiation is dependent upon X-ray Head shielding package, see options in section 4.2.

3.2.2 RF Unit / X-ray Head

The temperature range for X-ray head / RF unit is -40/52°C (-40/125°F), with condensing humidity.

3.2.3 Temperature Control Unit (TCU)

TCU temperature range is -40/+55°C (-40/131°F), with condensing humidity.

Table 1 - X-Ray Beam Characteristics				
Model	Nominal Energy (MV)	Half Value Layer (Inches of Steel)	Flatness (% @ ± 7.5°)	Max. Dose Rate (Gy/Min)
M6/ M6A	4.0	1.00"	≥69.0	2.5
	5.0	1.06"	≥65.5	5.0
	6.0	1.10"	≥62.0	8.0
*Dose rate will be affected by customer collimation and flattening filter, if applicable.				

3.0 Customer Facility Requirements

3.1 Electrical Requirements

The Linatron M operates from a single 15 kVA power source. Two voltage ranges are available.

- 208 VAC ±10%, 3-phase, Delta (4-wire), 50 or 60 Hz
- 400 VAC ±10%, 3-phase, Wye, (5 wire), 50 or 60 Hz

3.1.1 Temperature Control Unit (TCU)

The TCU is connected to a separate 7kVA power source. Models are available that can operate on a line voltage of 220 VAC and 400 VAC, at 50Hz; or 220 VAC and 480 VAC, at 60Hz. If the in-line heater package is required, power requirement is increased to 20kVA.

3.2 Operating Environment

3.2.1 Modulator / Console

The temperature range for console and modulator is 4/40°C (39/104°F), with 90% maximum relative humidity (non-condensing). Indoor use only.

4.0 Optional Equipment

4.1 Custom Beam Collimation

Non-standard field sizes are available per customer's requirements. Motorized collimator options are also available to quickly change the beam collimation.

4.1.1 Internal Collimator Options

Table 2 - Field Collimator Options			
Cone	Min	4°	Note Symmetric
	Max*	67° (39°)	
	Standard	15°, 30°	
Slit	Min	±2°	Note Vertical Angles may be asymmetrical
	Max	+35°/-32°	
	Width	2.5mm-6mm	
Square/ Fan	Min	±2	Note All Angles may be asymmetrical
	Max*	±39° (±19.5°)	
	Standard	22.5°, 24°	
*Ultra-Low Leakage Package limits collimator angles to those shown in parenthesis			

4.1.2 Dependent Jaw External Collimator

The dependent jaw external collimator is available in a fixed or rotational version. The jaws in each orientation open symmetrically to produce a field size from 1° to 24°. The rotating version can rotate over a range from -45° to +45°.

4.1.3 Independent Jaw External Collimator

The independent jaw external collimator is available in a non-rotatable version. It includes a mechanically stowable laser alignment system. The jaws open asymmetrically to produce a field size from 1° to 24°. Its laser is 635nm, Class II, <1mW.

Linatron M6 & M6A

Modular High-energy X-Ray Source



4.2 Lower Leakage Options listed in Table 3

Table 3 - Leakage Radiation Shielding Options			
Model	Shielding Package	Leakage (Fraction)	RFU / X-Ray Head Weight (lbs.)
M6/ M6A	Low Leakage	1.0×10^{-3}	1711 ± 25
	Super Low Leakage	2.0×10^{-5}	2075 ± 25
	Ultra-Low Leakage*	2.5×10^{-6}	5175 ± 25
*Ultra-Low Leakage Package not available with Laser or External Collimator Options			

4.3 Power Options

Recommended for installations where line power short-term fluctuations are greater than +/-5%. A step-up or step-down transformer can also be ordered to adapt a non-standard voltage source for use with the Linatron or TCU. The regulator is CE and UL approved.

4.4 Beam Flattener

This option provides a more uniform beam intensity over the exposed region at 3.0 MeV. Use of a flattening filter will reduce dose rate.

4.5 Laser Alignment System

An internally mounted single spot laser is available to align the X-ray beam to an object being radiographed. Not available with ULLP leakage option. Laser is 533 nm, Class II, 0.5 mW.

4.6 Remote Customer Interface

A 37-pin Amphenol socket is provided on the modulator for interface to customers equipment. For a complete description of these signals, request document #100015302.

Signals include:

- External Trigger
- Emergency Off
- Remote Interlock
- Warning Lights
- Warning Alarm
- X-ray on Request
- Warm Up and Power On Status
- Fault Information and Reset

4.7 Imaging Control Unit (ICU) - Flat Panel Interface

An optional Imaging Control Unit (ICU) is available to provide interface with 4343HE and other flat panel radiation detector. All required power and modulator signal cables are included with this option.

4.8 Smart Remote Customer Interface

The Linatron uses industry standard Modbus Client/Server Protocol, configurable as RTU via serial interface or TCP via Ethernet. The customer can use a personal computer or utilize a primary control system to control/monitor the Linatron. The signals available include control, fault monitoring and analog input signals. Modbus option is not configurable as RTU with the Independent Jaw External Collimator installed.

Quality

Varex Imaging Corporation, Las Vegas is an ISO 9001 registered facility.



Regulatory Compliance CE Marking

All M-Series Linatron models have been tested and meet all Varex Imaging Quality specifications and are in conformity with following standards for safety and EMC requirements.

Safety

IEC / EN 61010-1 Safety requirements for electrical equipment for measurement, control, and laboratory use
ANSI / UL / CSA C22.2 No. 61010-1

Electromagnetic Compatibility (EMC)

FCC CFR Title 47 Part 18 Rules Conducted & Radiated Emissions

CISPR 11 / EN 55011 Conducted & Radiated Emissions

European Union Directives

- 2014/35/EU Low Voltage Directive
- 2014/30/EU EMC Directive
- 2011/65/EU Reduction of Hazardous Substances (RoHS)

Linatron M6 & M6A

Modular High-energy X-Ray Source



M6 PHYSICAL CONFIGURATIONS

Control Console
(9 lbs)

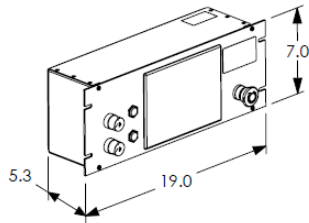

Modulator
735 ± 25 lbs

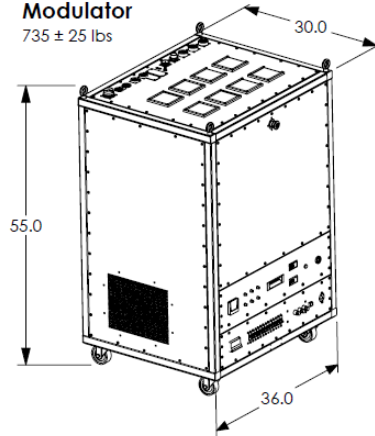

M6 SUPER LOW LEAKAGE			
PARAMETERS	X	Y	Z
CENTER OF GRAVITY	17.4	10.5	12.7
FOCAL POINT	9.6	9.5	9.3
TOTAL WEIGHT: 2075 ± 25 LBS			

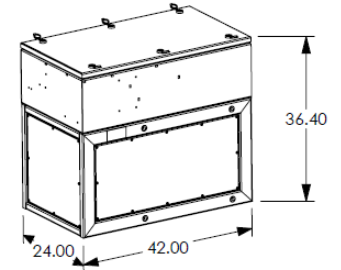

Temperature Control Unit (TCU)
(567 lbs, max)

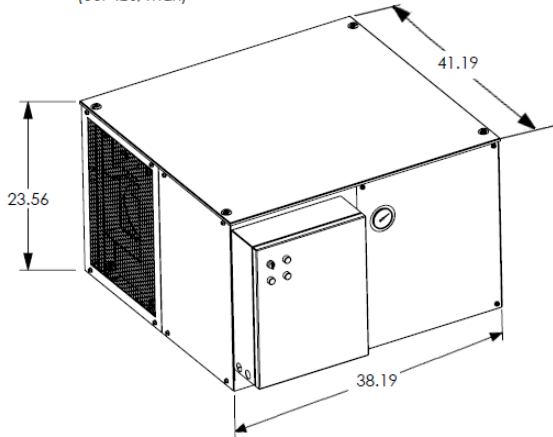

M6 LOW LEAKAGE			
PARAMETERS	X	Y	Z
CENTER OF GRAVITY	18.9	10.7	13.8
FOCAL POINT	9.6	9.5	9.3
TOTAL WEIGHT: 1711 ± 25 LBS			

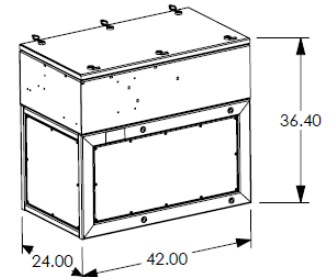

M6 ULTRA LOW LEAKAGE			
PARAMETERS	X	Y	Z
CENTER OF GRAVITY	18.6	16.0	13.5
FOCAL POINT	9.8	15.6	9.5
TOTAL WEIGHT: 5175 ± 25 LBS			

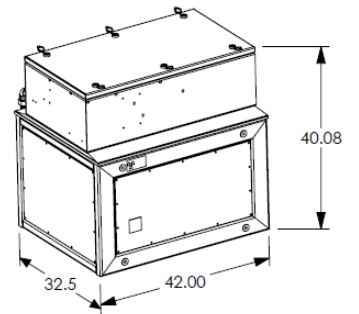

Varex Imaging and Linatron are registered trademarks, and Linatron M is a trademark of Varex Imaging Corporation.
All other trademarks are the property of their respective owners.

Varex Imaging Corporation

USA

HEADQUARTERS
Salt Lake City, UT
P: +1-801-972-5000



Las Vegas, NV
Tel: 1-800-432-4422
Email: industrial.support@vareximaging.com
Website: <https://www.vareximaging.com/solutions/security-industrial-solutions>

©2020 Varex Imaging Corporation. All Rights reserved. Production of any of the material contained herein in any format or media without the express written permission of Varex Imaging Corporation is prohibited.