

HPC-225-FB-BE

Stationary Anode X-Ray Tube



Product Description

The HPC-225-FB-BE is a 225 kV, water cooled stationary anode metal ceramic X-ray source. This source is designed for NDT imaging applications.

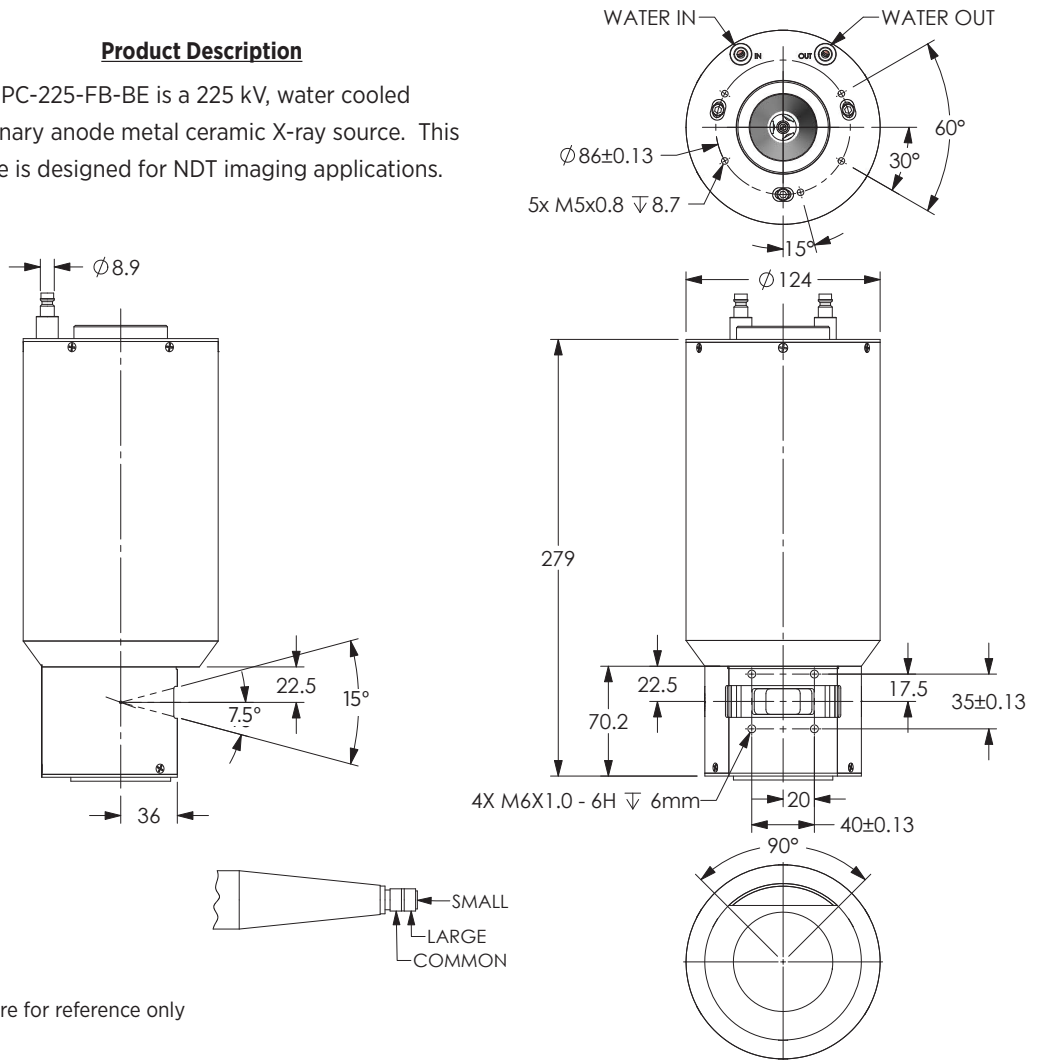

Dimensions are for reference only

X-Ray Tube Specifications

Maximum Tube Voltage	225 kV	Cooling Medium	50/50 mix of Glycol and Water
Minimum Tube Voltage	30 kV	Reference Axis	Perpendicular to port face
Maximum mA at 225 kV	13.0 mA	Nominal Radiation Coverage	90° x 15°
Typical Operating Conditions.....	225 kV, 13 mA	Load Factors for Leakage Radiation	225 kV, 13.0 mA
Focal Spot (EN 12543)		Maximum Radiation Leakage.....	10 µSv/h @ 1 meter
Large	D = 5.5 mm	X-Ray Tube Assembly Permanent Filtration	2.0 mm Be
Target Angle	20°	High Voltage Receptacle Type	R-24
Maximum Continuous Rating		Nominal Mass	10.5 kg (23.1 lbs)
Large	3000 W with 4 Liter/min cooling flow	Idle Filament Current (maximum).....	1.40 Amps
Temperature at fluid inlet (maximum)	35°C		

Tube Voltage (kV)	Power (Watts)					
	500	1000	1500	2000	2500	3000
30	16.67	33.33	50.00			
60	8.33	16.67	25.00	33.33	41.67	50.00
75	6.67	13.33	20.00	26.67	33.33	40.00
100	5.00	10.00	15.00	20.00	25.00	30.00
150	3.33	6.67	10.00	13.33	16.67	20.00
175	2.86	5.71	8.57	11.43	14.29	17.14
200	2.50	5.00	7.50	10.00	12.50	15.00
225	2.22	4.44	6.67	8.89	11.11	13.33

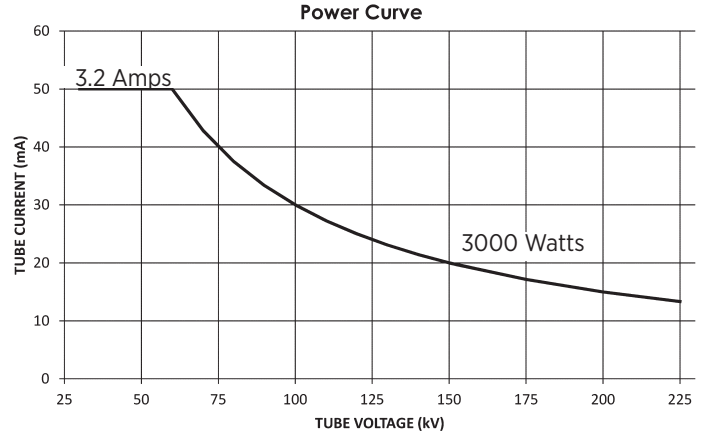

Instructions for Operation

General

The control of the high voltage and the filament current as well as the design of the cooling unit is the responsibility of the equipment manufacturer.

High Voltage Connection

One terminal type R24 high voltage cables supply high voltage and filament current.

Two different methods of mounting the high voltage cable are available.

1. Mounting flange requiring 4 mm gap for DSI and Essex cables and 6 mm for Claymount cables, as illustrated in tube operating manual.
2. Spring loaded cable head, 2 rings showing, as illustrated in the tube operating manual.

Anode Cooling and Coolant Flow

It is the user's responsibility to ensure that the cooling medium flow rates are met under all operating conditions including tube start-up. Failure to meet flow rate requirements can lead to anode destruction and tube failure.

Control of Cooling Medium

Flow and temperature of the cooling medium at the inlet to the tube assembly must be appropriately monitored. High voltage must be terminated when the pressure or flow rate falls below the minimum level or when the temperature exceeds the maximum level. When power to the X-ray tube is switched off, the coolant flow must continue for at least 2 minutes in order to protect the anode from damage.

NOTE: For further information and troubleshooting, refer to the tube Operating Manual.



WARNING

Beryllium windows transmit a very high level of long wavelength X-radiation, which can injure human tissue. Injury may occur from even very short exposures to the primary X-ray beam. Follow all precautions necessary to avoid radiation exposure to humans.

The radiation dose rate cannot be accurately measured with conventional radiation measurement instruments. Radiation intensity in each installation will vary, and calibration must include the effects of long wavelength X-radiation.

Fumes from beryllium metal (or its compounds) as well as dust can be hazardous if inhaled. During use, corrosion products may occur on the beryllium window, but these should not be scraped off, machined, or otherwise removed. Tube unit disposal should conform to federal, state, and local regulations governing beryllium.