

Rotating Anode X-Ray Tube Tubes  
Radiogènes à Anode Tournante  
Drehanoden - Röntgenröhre  
Tubos de Rayos-X con Ánodo Giratorio

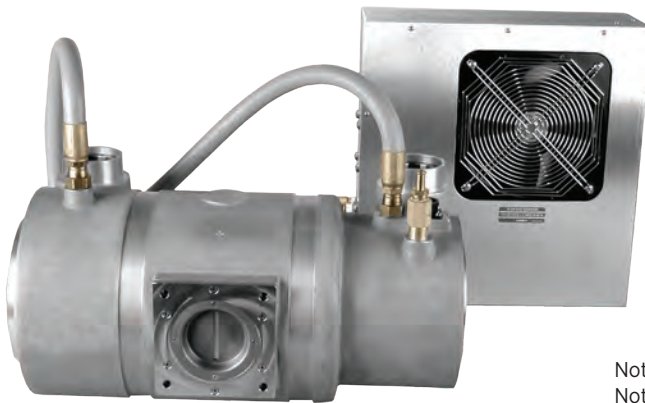

Note: Document originally drafted in the English language.

Note : Document à l'origine rédigé dans l'anglais.

Anmerkung: Dokument ursprünglich gezeichnet in der englischen Sprache.

Nota: Documento elaborado originalmente en la lengua inglesa.

Product Description	Description du Produit	Produktbeschreibung	Descripcion del Producto
<p>The GS-45715 is a 6.5" (166 mm) 150 kV, 3.57 MJ (5.0 MHU) maximum anode heat content, rotating anode insert. The insert features a 7° tungsten-rhenium facing on molybdenum with a graphite backed target and is available with the following nominal focal spots:</p>	<p>Le tube GS-45715, est une tube à anode tournante de plateau 166 mm, (6,5 pouces), 150 kV, d'une capacité thermique de 3,57 MJ (5,0 MUC). Le pente de l'anode en molybdène traitée, tungstène, rhénium, recouverte de graphite, est de 7°. La dimension des foyers est de:</p>	<p>Die GS-45715 ist eine 166 mm (6.5") Doppelfokus Drehanoden-Röntgenröhre, mit einer Anoden Wärmespeicherkapazität von 3.57 MJ (5.0 MHU) und einer max. Spannungsfestigkeit von 150 kV. Der rückseitig mit Graphit beschichtete Wolfram-Rhenium-Molybdän Anodenteller besitzt einen Winkel von 7°. Folgende Brennfleck sind lieferbar:</p>	<p>El GS-45715 es un tubo de ánodo giratorio de 166 mm (6.5"), 150 kV, 3.57 MJ (5.0 MHU), la cual es el máximo almacenaje térmico del ánodo. El blanco emisor es una combinación de tungsteno, renio y molibdeno con grafito en la parte posterior con un rayo central de 7 grados. Disponible con las siguientes marcas focales:</p>
<p>0.7 x 0.8 1.2 x 1.4 IEC 60336</p>	<p>0,7 x 0,8 1,2 x 1,4 CEI 60336</p>	<p>0.7 x 0.8 1.2 x 1.4 IEC 60336</p>	<p>0.7 x 0.8 1.2 x 1.4 IEC 60336</p>
<p><b>Loading Factor for slit focal:</b> Small - 120 kV, 100 mA Large - 120 kV, 200 mA</p>	<p><b>Facteur de charge pour foyer à fente:</b> Petit - 120 kV, 100 mA Grand - 120 kV, 200 mA</p>	<p><b>Ladefaktor:</b> Klein - 120 kV, 100 mA Gross - 120 kV, 200 mA</p>	<p><b>Carga Eléctrica Para la Abertura Focal:</b> Pequeño - 120 kV, 100 mA Grande - 120 kV, 200 mA</p>
<p><b>Maximum Anode Cooling Rate:</b> 8,900 W (12,460 HU/sec)</p>	<p><b>Taux maximum de refroidissement de l'anode:</b> 8,900 W (12,460 UC/sec)</p>	<p><b>Nennleistung der Anode:</b> 8,900 W (12,460 HU/sek)</p>	<p><b>Medida Máxima del Enfriamiento del Anodo:</b> 8,900 W (12,460 HU/seg)</p>
<p><b>Maximum continuous anode heat dissipation:</b> 5,600 W (7,840 HU/sec)</p>	<p><b>Description calorifique maximum de l'anode (en continu):</b> 5,600 W (7,840 UC/sec)</p>	<p><b>Maximale kontinuierliche Wärmeableitung des Anodentellers:</b> 5,600 W (7,840 HU/sek)</p>	<p><b>Maxima disipación térmica continua del Anodo:</b> 5,600 W (7,840 HU/seg)</p>
<p><b>Nominal CT Anode Input Power:</b> Small - 28 kW IEC 60613:2010 Large - 48 kW IEC 60613:2010</p>	<p><b>Puissance appliquée à l'anode nominale de CT:</b> Petit - 28 kW CEI 60613:2010 Grand - 48 kW CEI 60613:2010</p>	<p><b>CT Anoden Eingangs-Nennleistung:</b> Klein - 28 kW IEC 60613:2010 Gross - 48 kW IEC 60613:2010</p>	<p><b>Potencia nominal de entrada CT del ánodo:</b> Pequeño - 28 kW IEC 60613:2010 Grande - 48 kW IEC 60613:2010</p>
<p><b>Nominal CT Scan Power Index:</b> Small - 28 kW IEC 60613:2010 Large - 45.4 kW IEC 60613:2010</p>	<p><b>Index nominal de puissance de balayage de CT:</b> Petit - 28 kW CEI 60613:2010 Grand - 45,4 kW CEI 60613:2010</p>	<p><b>CT Scan Nennleistungsindex:</b> Klein - 28 kW IEC 60613:2010 Gross - 45.4 kW IEC 60613:2010</p>	<p><b>Índice de potencia nominal exposiciones CT:</b> Pequeño - 28 kW IEC 60613:2010 Grande - 45.4 kW IEC 60613:2010</p>
<p><b>Reference Axis:</b> Perpendicular to port face.</p>	<p><b>Référence axe:</b> Perpendiculaire à la face de sortie.</p>	<p><b>Referenz Achsen:</b> Senkrecht zum Strahlenaustrittsfenster.</p>	<p><b>Referencia de axes:</b> Perpendicular a la abertura facial.</p>
<p>This insert is intended for use in Varex Imaging B-421H housing.</p>	<p>Ce tube est essentiellement destiné à être employé dans les gaines Varex Imaging des séries B-421H.</p>	<p>Die Röntgenröhre ist für den Einbau in die Varex Imaging Strahlerröhre B-421H vorgesehen.</p>	<p>Este tubo es diseñado, para uso en los encajes Varex Imaging de la serie B-421H.</p>

Volumetric / Helical Scan Ratings IEC 60613  
 Tableaux des Caractéristiques Nominales de Balayage Volumétrique/Hélicoïdal CEI 60613  
 Volumen-/Spiralbelichtungs-Leistungdiagramme IEC 60613  
 Volumétrico/Clasificación Grafica del Escán/Helicoideo IEC 60613

### 30 60 Hz



0.7 x 0.8 Focal Spot 7 Degrees  
 0.7 x 0.8 Dimension Focale 7 Degrés  
 0.7 x 0.8 Brennfleck 7 Grad  
 0.7 x 0.8 De Marcas Focales 7 Grados

Volume scan time (seconds)	Maximum allowed tube current (mA) as a function of the following starting heat storage and tube voltages								
	Starting heat storage = 40 %			Starting heat storage = 55 %			Starting heat storage = 70 %		
	100 kV	120 kV	130 kV	100 kV	120 kV	130 kV	100 kV	120 kV	130 kV
4	215	180	165	215	180	165	215	180	165
10	215	180	165	215	180	165	215	180	165
20	215	180	165	215	180	165	215	180	165
30	215	180	165	215	180	165	215	180	165
40	215	180	165	215	180	165	170 (a)	140 (a)	130 (a)
50	215	180	165	215	180	165	140 (a)	115 (a)	105 (a)
60	215	180	165	185 (a)	155 (a)	140 (a)	120 (a)	100 (a)	95 (a)
70	215	180	165	160 (a)	135 (a)	125 (a)	110 (a)	90 (a)	80 (a)
80	190 (a)	160 (a)	145 (a)	145 (a)	120 (a)	110 (a)	100 (a)	80 (a)	75 (a)
100	155 (a)	130 (a)	120 (a)	120 (a)	100 (a)	90 (a)	85 (a)	70 (a)	65 (a)

### 30 120 Hz



0.7 x 0.8 Focal Spot 7 Degrees  
 0.7 x 0.8 Dimension Focale 7 Degrés  
 0.7 x 0.8 Brennfleck 7 Grad  
 0.7 x 0.8 De Marcas Focales 7 Grados

Volume scan time (seconds)	Maximum allowed tube current (mA) as a function of the following starting heat storage and tube voltages								
	Starting heat storage = 40 %			Starting heat storage = 55 %			Starting heat storage = 70 %		
	100 kV	120 kV	130 kV	100 kV	120 kV	130 kV	100 kV	120 kV	130 kV
4	280	235	215	280	235	215	280	235	215
10	280	235	215	280	235	215	280	235	215
20	280	235	215	280	235	215	280	235	215
30	280	235	215	280	235	215	215 (a)	180 (a)	165 (a)
40	280	235	215	265 (a)	220 (a)	205 (a)	170 (a)	140 (a)	130 (a)
50	280	235	215	220 (a)	180 (a)	165 (a)	140 (a)	115 (a)	105 (a)
60	250 (a)	210 (a)	190 (a)	185 (a)	155 (a)	140 (a)	120 (a)	100 (a)	95 (a)
70	215 (a)	180 (a)	165 (a)	160 (a)	135 (a)	125 (a)	110 (a)	90 (a)	80 (a)
80	190 (a)	160 (a)	145 (a)	145 (a)	120 (a)	110 (a)	100 (a)	80 (a)	75 (a)
100	155 (a)	130 (a)	120 (a)	120 (a)	100 (a)	90 (a)	85 (a)	70 (a)	65 (a)

### 30 60 Hz



1.2 x 1.4 Focal Spot 7 Degrees  
 1.2 x 1.4 Dimension Focale 7 Degrés  
 1.2 x 1.4 Brennfleck 7 Grad  
 1.2 x 1.4 De Marcas Focales 7 Grados

Volume scan time (seconds)	Maximum allowed tube current (mA) as a function of the following starting heat storage and tube voltages								
	Starting heat storage = 40 %			Starting heat storage = 55 %			Starting heat storage = 70 %		
	100 kV	120 kV	130 kV	100 kV	120 kV	130 kV	100 kV	120 kV	130 kV
4	420	350	320	420	350	320	420	350	320
10	420	350	320	420	350	320	420	350	320
20	420 (b)	350 (b)	320 (b)	415	345	320	305 (a)	255 (a)	235 (a)
30	420 (b)	350 (b)	320 (b)	350 (a)	290 (a)	265 (a)	215 (a)	180 (a)	165 (a)
40	360 (b)	300 (b)	275 (b)	265 (a)	220 (a)	205 (a)	170 (a)	140 (a)	130 (a)
50	295 (a)	245 (a)	230 (a)	220 (a)	180 (a)	165 (a)	140 (a)	115 (a)	105 (a)
60	250 (a)	210 (a)	190 (a)	185 (a)	155 (a)	140 (a)	120 (a)	100 (a)	95 (a)
70	215 (a)	180 (a)	165 (a)	160 (a)	135 (a)	125 (a)	110 (a)	90 (a)	80 (a)
80	190 (a)	160 (a)	145 (a)	145 (a)	120 (a)	110 (a)	100 (a)	80 (a)	75 (a)
100	155 (a)	130 (a)	120 (a)	120 (a)	100 (a)	90 (a)	85 (a)	70 (a)	65 (a)

### 30 120 Hz



1.2 x 1.4 Focal Spot 7 Degrees  
 1.2 x 1.4 Dimension Focale 7 Degrés  
 1.2 x 1.4 Brennfleck 7 Grad  
 1.2 x 1.4 De Marcas Focales 7 Grados

Volume scan time (seconds)	Maximum allowed tube current (mA) as a function of the following starting heat storage and tube voltages								
	Starting heat storage = 40 %			Starting heat storage = 55 %			Starting heat storage = 70 %		
	100 kV	120 kV	130 kV	100 kV	120 kV	130 kV	100 kV	120 kV	130 kV
4	480 (b)	400 (b)	365 (b)	480 (b)	400 (b)	365 (b)	480 (b)	400 (b)	365 (b)
10	480 (b)	400 (b)	365 (b)	480 (b)	400 (b)	365 (b)	480 (b)	400 (b)	365 (b)
20	420 (b)	350 (b)	320 (b)	420 (b)	350 (b)	320 (b)	310 (a)	255 (a)	235 (a)
30	420 (b)	350 (b)	320 (b)	350 (a)	290 (a)	265 (a)	215 (a)	180 (a)	165 (a)
40	360 (b)	300 (b)	275 (b)	265 (a)	220 (a)	205 (a)	170 (a)	140 (a)	130 (a)
50	295 (a)	245 (a)	230 (a)	220 (a)	180 (a)	165 (a)	140 (a)	115 (a)	105 (a)
60	250 (a)	210 (a)	190 (a)	185 (a)	155 (a)	140 (a)	120 (a)	100 (a)	95 (a)
70	215 (a)	180 (a)	165 (a)	160 (a)	135 (a)	125 (a)	110 (a)	90 (a)	80 (a)
80	190 (a)	160 (a)	145 (a)	145 (a)	120 (a)	110 (a)	100 (a)	80 (a)	75 (a)
100	155 (a)	130 (a)	120 (a)	120 (a)	100 (a)	90 (a)	85 (a)	70 (a)	65 (a)

**Note:**  
 1. Limits are based on maximum track rating except for the following codes:  
 a - Limited by available heat storage.  
 b - Limited by window heating.  
 c - Limited by filament emission.  
 2. H.S. = Heat Storage  
 kV = Tube Voltage

**Remarque:**  
 1. Les limites sont fonction de l'indice maximal de surface de l'anode, sauf pour les codes suivants:  
 a - Limité par le stockage thermique disponible.  
 b - Limité par le chauffage de la fenêtre.  
 c - Limité par le rayonnement des filaments.  
 2. H.S. = Stockage Thermique  
 kV = Tube Voltage

**Anmerkungen:**  
 1. Grenzwerte basieren auf der maximalen Anodenoberflächenleistung mit Ausnahme der folgenden Codes:  
 a. Durch verfügbare Wärmekapazität begrenzt.  
 b. Durch Öffnungserwärmung begrenzt.  
 c. Durch Glühfadenemission begrenzt.  
 2. H.S. = Wärmekapazität  
 kV = Röhre Spannung

**Nota:**  
 1. La clasificación de la marca maxima son limitadas, excepto por los siguientes codigos:  
 a. Limitado por el almacenaje de calor disponible.  
 b. Limitado por el calor de conducción de la ventana.  
 c. Limitado por la emisión del filamento.  
 2. H.S. = Almacenaje de calor  
 kV = Tubo Voltaje

**Note:**  
 Rating charts reflect maximum tube performance. Tube operation is ultimately limited by system software.

**Remarque:**  
 Abaques de caractéristiques représentent des valeurs maximales. L'utilisation du tube est finalement limitée par le logiciel du système.

**Anmerkungen:**  
 Die leistungsdiagramme zeigen die maximale Röhrenleistung. Der Röhrenbetrieb ist ultimativ zu begrenzen durch die Systemkontrollsoftware.

**Nota:**  
 El máximo poder del tubo es reflectada en el clasificación diagrama. La operación del tubo es ultimamente limitada por el control del sistema programado.

3 Ø ---

Cathode Emission Characteristics Charts IEC 60613  
 Caractéristiques d'Émission du Filament CEI 60613  
 Kathoden - Emissionskennlinien IEC 60613  
 Características de Emisión del Catodo IEC 60613

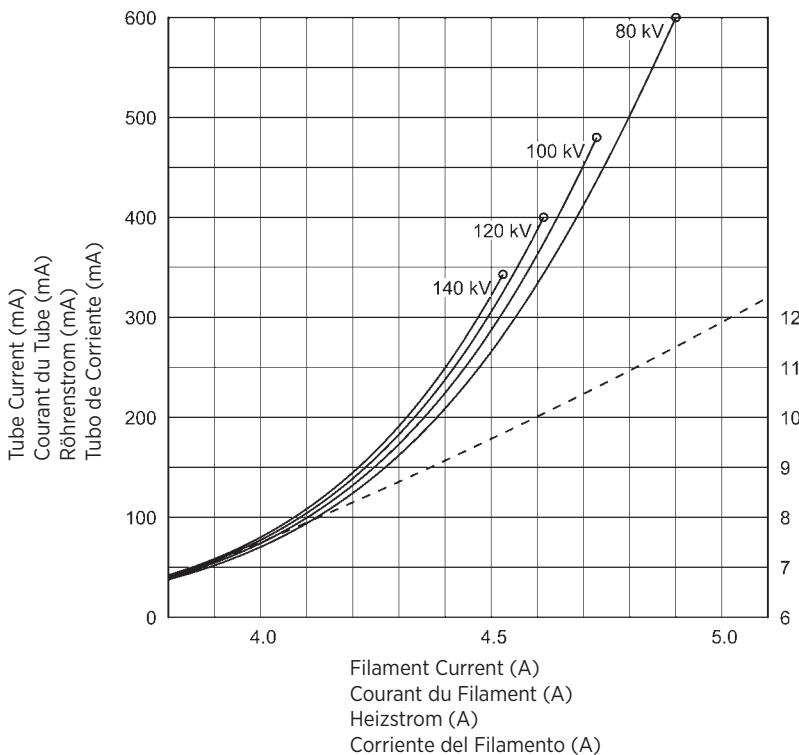
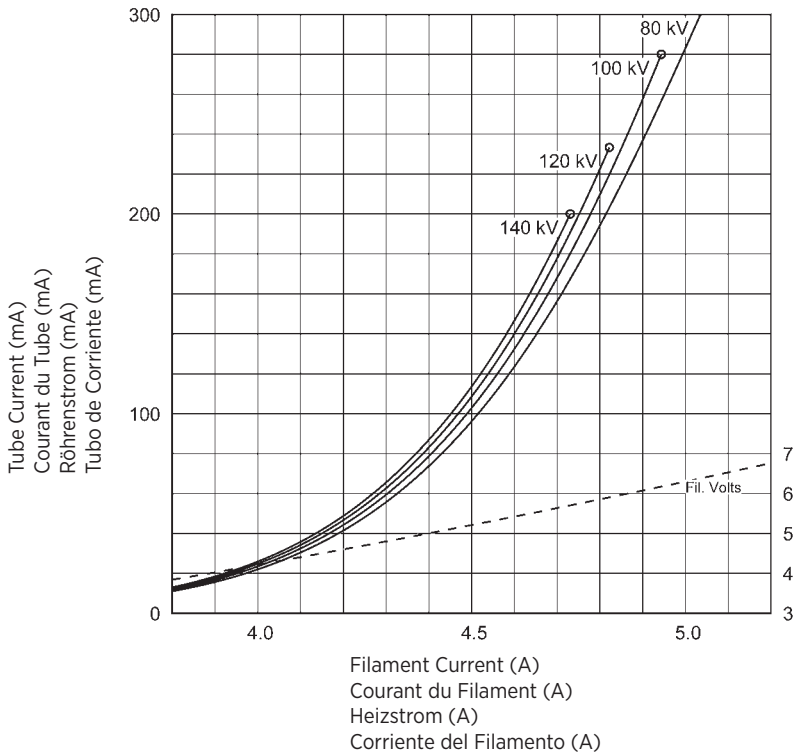

Maximum Peak Voltage	150 kV
Anode to Ground	75 kV
Cathode to Ground	75 kV
Maximum X-ray Tube Assembly Heat Content	4.85 MJ (6.8 MHU)
Nominal Continuous Input Power (max. housing temperature 78°C) (Includes all sources)	5.7 kW (7.98 kHU/sec) IEC 60613:2010
Maximum Heat Exchanger Dissipation	6.3 kW (8.5 kHU/sec)
Focal Point Position (Central Ray) Within 1mm (X, Y Direction from the center of radiation port.)	
X-Ray Tube Assembly	
Permanent filtration	1.0 mm Al IEC 60522/1999
Loading Factors for Leakage Radiation	150 kV, 37 mA
High Voltage Cable Receptacles	Per IEC 60526
Ambient Air Temperature Limits for Operation	5°C to 40°C Inside the Gantry, covers closed
Temperature Limits for Storage and Transport	-20°C to +70°C
Humidity	10% - 90%
Atmospheric Pressure Range	70 kPa to 106 kPa
Weight - Total Unit Weight	67.1 kg (148 lbs)
IEC Classification	Class 1
Safety Devices - Thermal Switch	
Normally Closed Contact	Opening at 85°C ±3.9°C 500mA @ 50 VAC 100mA @ 120 VAC
Pressure Relief Valve	Opening at 25 PSI
Pressure Switch	
Normally Open contact	closes before 5.0 PSID Rising opens at 3.0 PSID ±0.2 PSID Falling
Filament Frequency Limits	50 HZ - 25 KHZ
Power Supply	DC

Tension maximale	150 kV
Tension Anode - Terre	75 kV
Tension Cathode - Terre	75 kV
Capacité Thermique Maximale de L'Ensemble Tube/Gaine	4,85 MJ (6,8 MUC)
Continue nominale Puissance d'entree (température maximale de la gaine à 78°C) (Inclut toutes les sources)	5,7 kW (7,98 kUC/sec) CEI 60613:2010
Dissipation Maximale de l'échangeur de chaleur	6,3 kW (8,5 kUC/sec)
Position du foyer (rayon central) à 1mm près (Coordonnées X, Y par rapport au centre du port de rayonnement.)	
Ensemble Radiogène	
Filtre non amovible	1.0 mm Al IEC 60522/1999
Facteur de Charge Poru Rayonnement de fuite	150 kV, 37 mA
Receptacules de câble haute tension	Par CEI 60526
Température Ambiante Pendant L'usage	5°C à 40°C A l'intérieur du Gantry, les couvertures fermées
Limites de Température Pour le Transport et Pour L'Emmasinage	-20°C à +70°C
Humidité	10% à 90%
Limites de pression atmosphérique	70 kPa à 106 kPa
Poids - Poids Spécifique Total	67.1 kg (148 lbs)
Classification CEI	Classe 1
Dispositifs de Sécurité - Switch Thermique	
Normalement Fermé	Ouverture à 85°C ±3.9°C 500mA @ 50 VAC 100mA @ 120 VAC
Valve de décompression	Ouverture à 25 PS
Interrupteur de pression	
Contact normalement ouvert	Fermé à 5.0 PSID d'augmentation S'ouvre 3.0 PSID ±0.2 chute
Limites de Fréquence des Filaments	50 HZ - 25 KHZ
Alimentation Demandée	Courant Continu

Maximale Spannungsfestigkeit	150 kV
Anode gegen Erde	75 kV
Kathode gegen Erde	75 kV
Maximale Wärmespeicherkapazität des Strahlergehäuses	4.85 MJ (6.8 MHU)
Kontinuierliche Eingangs-Nennleistung (max. Gehäusestemperatur 78°C) (einschliesslich aller Quellen)	5.7 kW (7.98 kHU/sek) IEC 60613:2010
Maximale Wärmeaustauscher - Verlustleistung	6.3 kW (8.5 kHU/sek)
Brennfleckposition (Zentralstrahl) innerhalb 1mm. (X-, Y-Achse von her mitte des Strahlenaustrittsfensters)	
Röntgenstrahlers	
Eigenfilterwert	1.0 mm Al IEC 60522/1999
Ladefaktoren für Leckstrahlungsmessung	150 kV, 37 mA
Hochspannungskabelbehälter	Pro IEC 60526
Umgebungstemperaturgrenzen für den Betrieb	5°C zu 40°C Im Inneren des Gantry, Abdeckungen geschlossen
Temperaturgrenzen für Aufbewahrung und Transport	-20°C zu +70°C
Feuchtigkeit	10% zu 90%
Luftdruck	70 kPa zu 106 kPa
Gewicht - GesamtMaßeinheit Gewicht	67.1 kg (148 lbs)
IEC Klassifizierung	Klasse 1
Sicherheitseinrichtungen - Thermoschalter	
normalerweise geschlossen Verbindung	Offen bei 85°C ±3.9°C 500mA @ 50 VAC 100mA @ 120 VAC
Druckablassventil	Offen bei 25 PSI
Kontakte normalerweise Offen	Schließt bei 5.0 PSID steigend Offen bei 3.0 PSID ±0.2 fallen
Heizfaden - Frequenzgrenze	50 HZ - 25 KHZ
Netzanschluß	DC

Tensión máxima	150 kV
Anodo a Tierra	75 kV
Catodo a Tierra	75 kV
Maximo Calor Contenido Ensamblaje del Tubo de Rayos X	4.85 MJ (6.8 MHU)
Potencia nominal de entrada continua (temperatura máxima de la encaje 78°C) (Incluye todas las fuentes)	5.7 kW (7.98 kHU/seg) IEC 60613:2010
Disipación maxima del radiador	6.3 kW (8.5 kHU/seg)
Posición de la marca focal (Rayo Central) Dentro de 1mm. (La Dirección axial X, Y se refiere del centro de la Radiación Portal.)	
Ensamblaje de Tubo de Rayos X	
Filtración Permanente	1.0 mm Al IEC 60522/1999
Especificaciones de Encaje para la fuga de Radiacion	150 kV, 37 mA
Receptáculo del cable de tensión	Por IEC 60526
Temperatura Limitada de Operación	5°C a 40°C Dentro del Gantry, las portadas están cerradas
Temperatura Limitada de Almacen y Transporte	-20°C a +70°C
Humedad	10% a 90%
Limites de la presión atmosférica	70 kPa a 106 kPa
Peso - Peso De Unidad Total	67.1 kg (148 lbs)
IEC Clasificación	Clase 1
Aparatos de Seguridad - Interruptor Termal	
Normalmente Cerrado	Abierto a 85°C ±3.9°C 500mA @ 50 VAC 100mA @ 120 VAC
Válvula de descarga de presión	Abierto a 25 PSI
Interruptor de Presión	
Contacto normalmente abierto	Cerrado a 5.0 PSID levantamiento Abre a 3.0 PSID ±0.2 cayend
Limites de la frecuencia del filamento	50 HZ - 25 KHZ
Suministrador-de-Poder	Corriente Directa

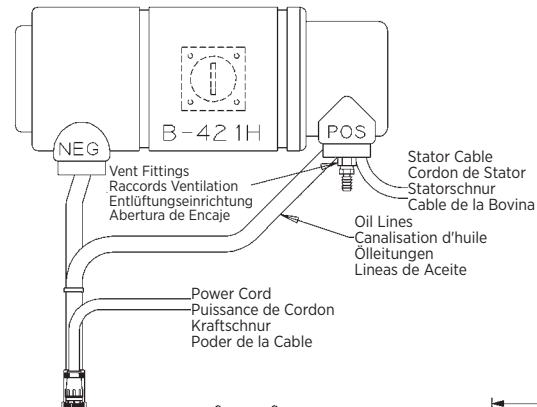

Dimensions are for reference only  
Les dimensions sont pour la référence seulement  
Maße sind als nur Referenz  
Las dimensiones están para la referencia solamente

Dimensions are in millimeters  
Les dimensions sont en millimètres  
Abmessungen sind in Millimetern  
Las dimensiones son en milímetros.

(As viewed, looking down into the receptacle)

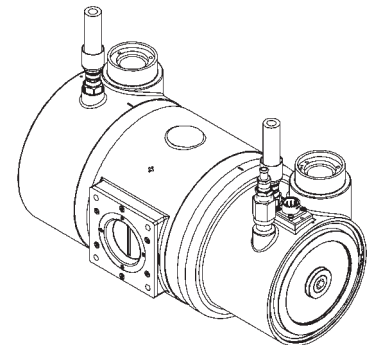
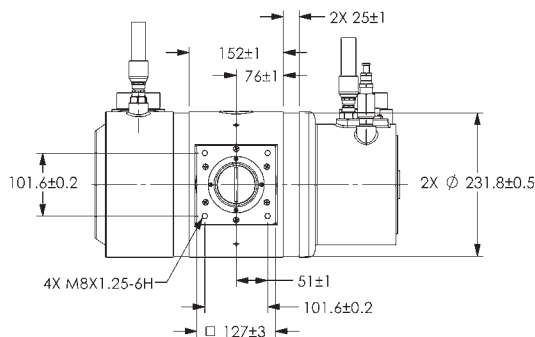
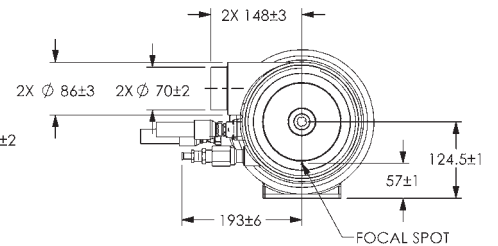
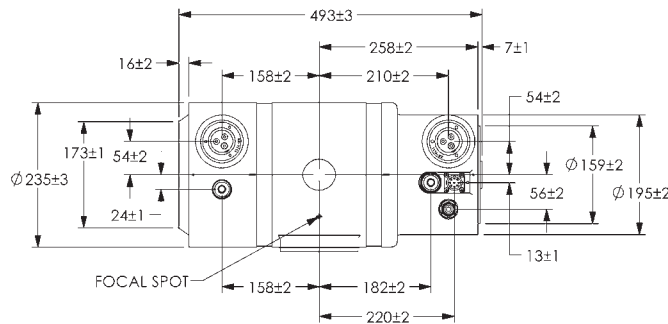
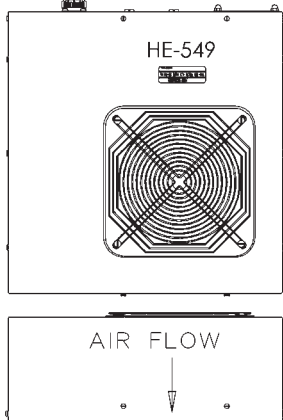
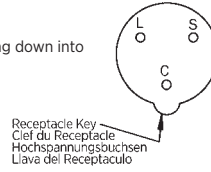

**HE-549**

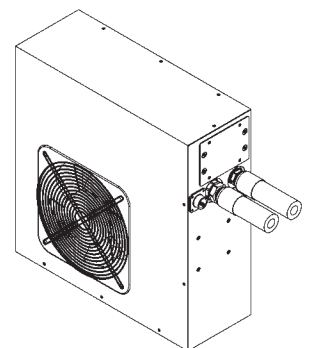
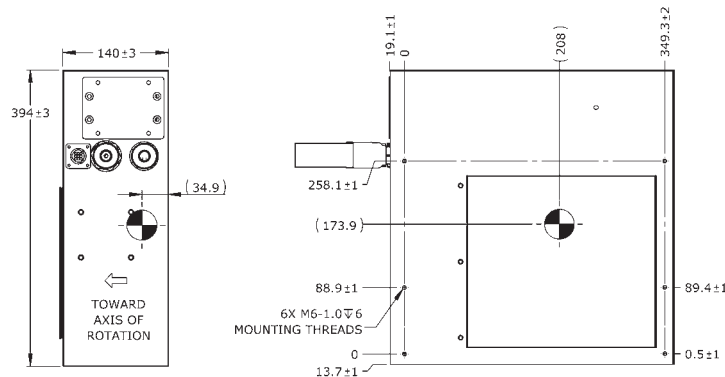
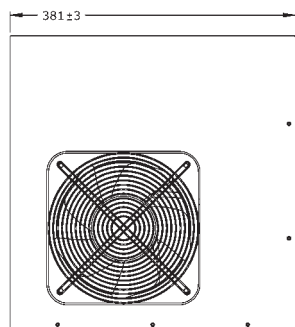
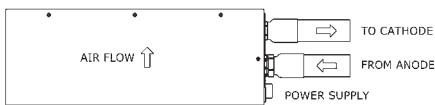

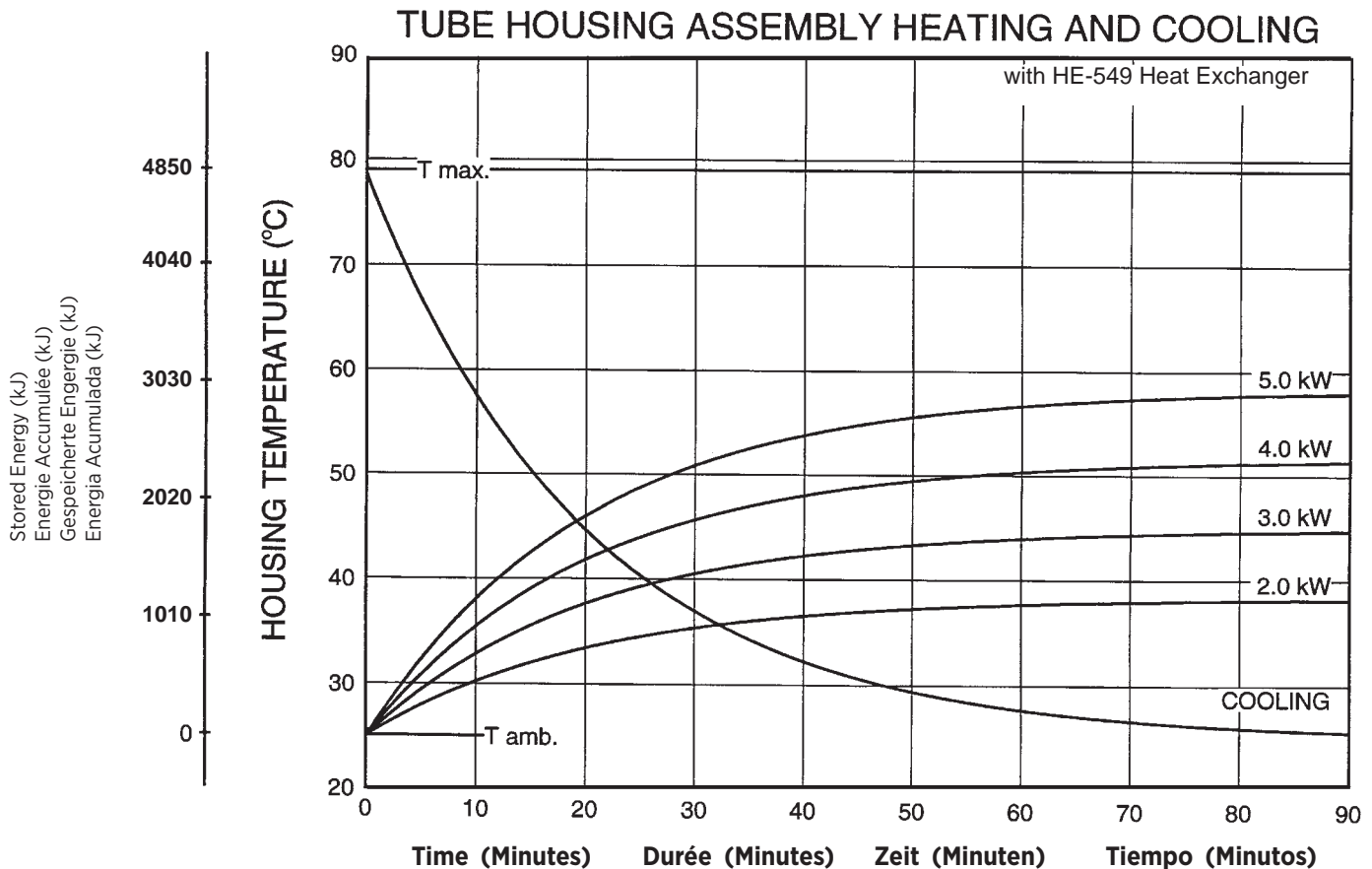

**Note:**

- Heat input into housing includes all power sources; tube, filament, stator and circulating pump.
- Heating curves based on no restrictions to air flow through heat exchanger, or natural convection around tube housing assembly.
- Heating and cooling curves reflect maximum tube performance. Tube operation is ultimately limited by system software control.

**Remarque:**

- L'entrée de chaleur dans la gaine comprend toutes les sources de puissance; tube, filament, stator et pompe circulante.
- Courbes de chauffage basées sur l'absence de restrictions à la circulation de l'air par l'échangeur de chaleur, ou convection naturelle autour de l'assemblage de boîtiers de tubes.
- Les abaques d'échauffement et de refroidissement représentent des valeurs maximales. L'utilisation du tube est finalement limitée par le logiciel du système.

**Anmerkungen:**

- Die Wärmeeingangsleistung des Strahlenschutzgehäuse umfasst alle Energiequellen, wie: Strahler, Heizfäden, Stator und Umwälzpumpe.
- Die Heizkurven basieren auf keinerlei Einschränkung durch den Wärmetauscher, oder der natürlichen Konvektion um das Strahlenschutzgehäuse.
- Die Angaben stellen die höchstzulässigen Betriebswerte dar. Der technische Betrieb muß im Rahmen der Belastungs- und Abkühlkennlinien erfolgen.

**Nota:**

- La entrada de calor en el encaje incluye todas las fuentes de alimentación; tubo, filamento, estator y bomba de circulación.
- Curvas de calentamiento sin ninguna restricción al flujo de aire a través del intercambiador de calor, o convección natural alrededor del conjunto de la coraza del tubo de rayos-x.
- El máximo poder del tubo es reflectada en el diagrama de enfriamiento y calentamiento del tubo es ultimamente limitada por el control del sistema programado.

Terminal / Wire Color Chart  
 Termiaux / Code Couleuru  
 Klemmen / Drahtfarbentabelle  
 Maja Del Alambre de Color Impulado / Terminal

Stator Ratings and Characteristics  
 Spécificités et Caractéristiques du Stator  
 Statornennleistungen und Merkmale  
 Características y Clarificación de la Bovina

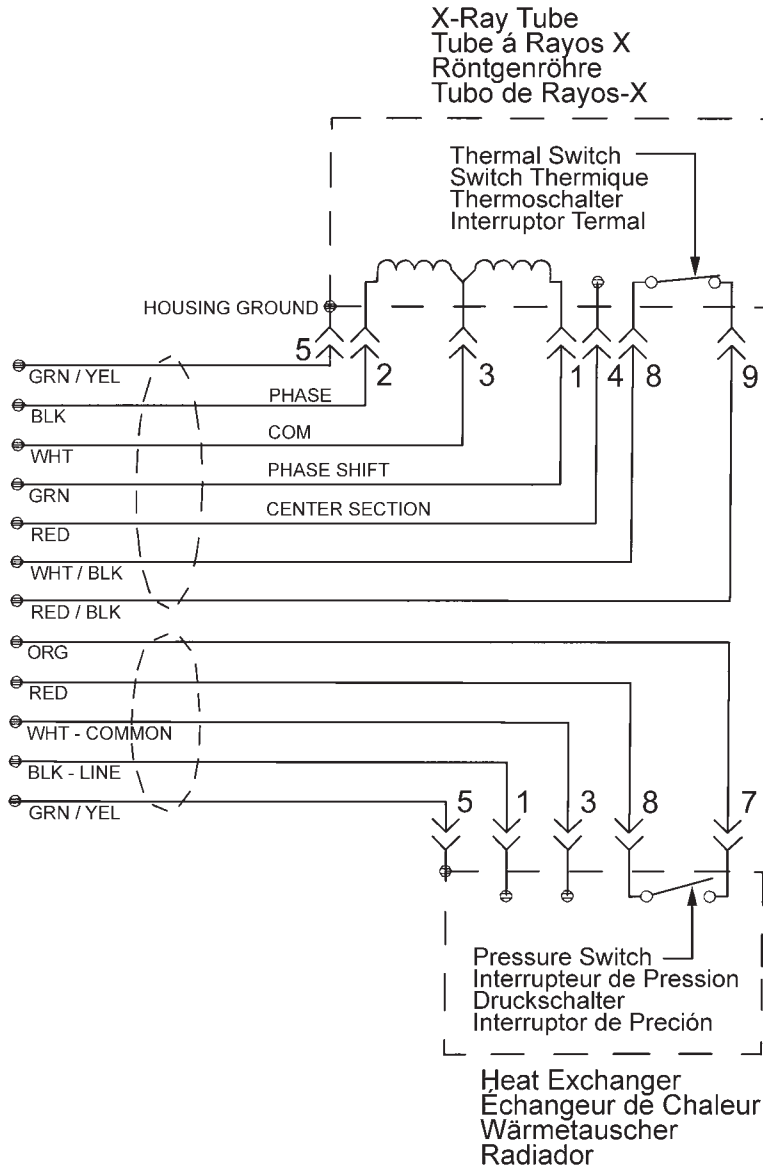

Wire Color Couleurs des Branchements Kabelfarben Cable de Color	Description Description Beschreibung Descripción
1 Green Vert Grün Verde	Phase Shift Changement de Phase Hilfsphase Cambio de Fase del Estator
2 Black Noir Schwarz Negro	Phase Phase Phase Fase
3 White Blanc Weiss Blanco	Common Neutre Neutral Común
4 Red Rouge Rot Rojo	Center Section Section Centrale Mittelteil Sección Central
5 Green/Yellow Vert/Jaune Grün/Gelb Verde/Amarillo	Housing Ground Masse de la Gaine Masse des Gehäuses Encaje a Tierra
8 White / Black Blanc / Noir Weiss / Schwarz Blanco / Negro	Thermal Switch Switch Therimque Thermoschalter Interruptor Termal
9 Red / Black Rouge / Noir Rot / Schwarz Rojo / Negro	Thermal Switch Switch Therimque Thermoschalter Interruptor Termal

Stator Drive Frequency Fréquence d'entraînement du stator Statorantrieb Frequenz Frecuencia de la impulsión del estator	RPM
60 Hz 120 Hz	3400 - 3600 6800 - 7200

<b>Stator Type:</b>		
<b>Stator Coil Resistance:</b>		
Black to White	14 Ohms ± 15%	
Green to White	46 Ohms ± 15%	
<b>Starter Voltage:</b>		
	<b>Start</b>	<b>Run</b>
60 Hz	220 VAC	85 VAC
120 Hz	470 VAC	140 VAC
<b>Time to Full Speed:</b>		
60 Hz	0 - 3400 RPM	11 Sec.
120 Hz	0 - 6800 RPM	10 Sec.
<b>X-Ray Tube Assembly:</b>		
GS-45715/B-421H	IEC 60601-2-28	

<b>Genre Stator:</b>		
<b>Résistance de la bobine du stator:</b>		
(résistance ohmique)		
Noir - Blanc	14 Ohms ± 15%	
Vert - Blanc	46 Ohms ± 15%	
<b>Tension de démarrage:</b>		
60 Hz	220 alternatif au démarrage	
	85 alternatif en maintien	
120 Hz	470 alternatif au démarrage	
	140 alternatif en maintien	
<b>Temps our atteindre la vitesse maximum:</b>		
60 Hz	de 0 à 3400 trs./mn	11 Sec.
120 Hz	de 0 à 6800 trs./mn	10 Sec.
<b>Ensemble radiogène:</b>		
GS-45715/B-421H	CEI 60601-2-28.	

<b>Statortyp:</b>		
<b>Stator - Spulenwiderstand</b>		
Schwarz - Weiss	14 Ohms ± 15%	
Grün - Weiss	46 Ohms ± 15%	
<b>Spannungen:</b>		
	<b>Anlauf</b>	<b>Weiterlauf</b>
60 Hz	220 VAC	85 VAC
120 Hz	470 VAC	140 VAC
<b>Hochlaufzeit:</b>		
60 Hz	0 - 3400 U/min	11 Sek.
120 Hz	0 - 6800 RPM	10 Sec.
<b>Röntgenstrahler:</b>		
GS-45715/B-421H	IEC 60601-2-28	

<b>Tipo de la Bovina:</b>		
<b>Resistencia del Rollo de la Bovina:</b>		
Negro a Blanco	14 Ohms ± 15%	
Verde a Blanco	46 Ohms ± 15%	
<b>Voltage de la Obtenida:</b>		
	<b>Empezar</b>	<b>Funcionar</b>
60 Hz	220 VAC	85 VAC
120 Hz	470 VAC	140 VAC
<b>Tiempo Para la Velocidad Maxima:</b>		
60 Hz	0 - 3400 RPM	11 Segundo
120 Hz	0 - 6800 RPM	10 Segundo
<b>Ensamblaje de Tubo de Rayos X:</b>		
GS-45715/B-421H	IEC 60601-2-28	

Anode Heating & Cooling Chart  
 Abaques d'Échauffement et de Refroidissement de L'Anode  
 Anoden Aufheiz- und Abkühl Kurven  
 Curvas de Calentamiento y Enfriamiento del Anodo

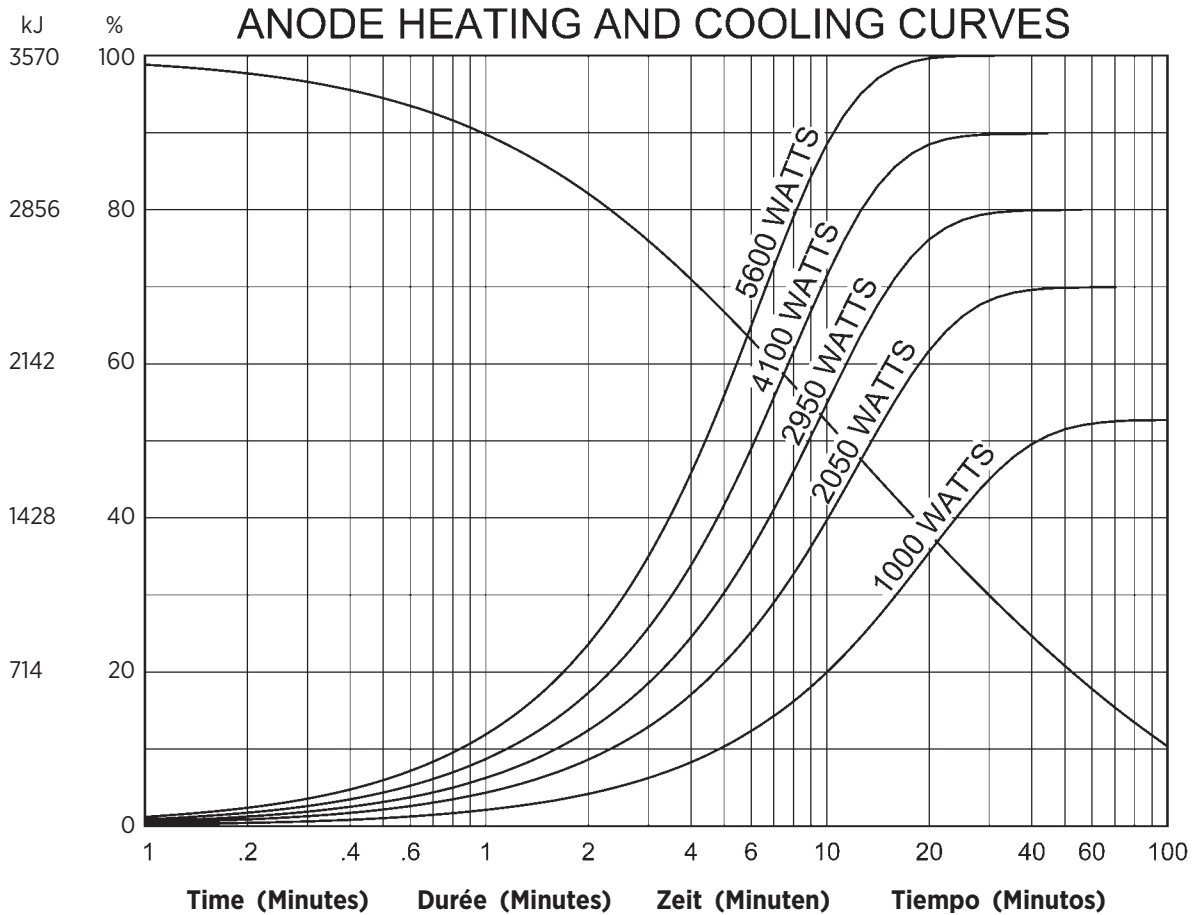

**Note:**  
 1. Heating and cooling curves reflect maximum tube performance. Tube operation is ultimately limited by system software control.

**Remarque:**  
 1. Les abaques d'échauffement et de refroidissement représentent des valeurs maximales. L'utilisation du tube est finalement limitée par le logiciel du système.

**Anmerkungen:**  
 1. Die Angaben stellen die höchstzulässigen Betriebswerte dar. Der technische Betrieb muß im Rahmen der Belastungs- und Abkühlkennlinien durchgeführt werden.

**Nota:**  
 1. El máximo poder del tubo es reflectada en el diagrama de enfriamiento y calentamiento del encaje ensamblado. La operación del tubo es ultimamente limitada por el control del sistema programado.