

DC-TDI

Photon Counting Detectors



Superior Image Quality with High Resolution
for Non-Destructive Testing

OVERVIEW

The DC-TDI series of industrial photon counting detectors are designed and optimized for high-speed scanning applications. The DC-TDI detectors natively support highly efficient scanning mode imaging, but they can also be operated in the frame read-out mode needed in, for example, helical CT applications.

High production line throughput can be maintained because of the advanced, direct conversion technology, which ensures excellent sensitivity. The images are true, high resolution and free of the blur typical of current scintillator-based detectors.

The detectors support native dual energy imaging with excellent spatial registration and energy separation. Energy information allows improved detection of foreign materials which appear very similar in conventional X-ray images.

The modular DC-TDI technology is available in many sizes and configurations for different applications using a wide range of X-ray energies.

FEATURES AND BENEFITS

- Scanning speed up to 120 m/min
- 100 μm resolution at all speeds
- Native dual energy imaging
- High efficiency
- Available in many sizes and energy options

APPLICATIONS¹

- Food inspection
- Waste sorting
- Battery
- Pipeline corrosion detection

SEEING MORE

The Varex Imaging photon counting technology sees more with less. The high sensitivity and noise free read-out allow the reduction of X-ray power or the use of lower power, smaller focal spot X-ray sources to fully exploit the high pixel resolution, even with additional magnification.

The DC-TDI detectors provide sharp images even at very fast imaging speed due to the absence of lag. This is true even in detector models intended for higher energy applications, which is not the case with conventional detectors.

Photon counting detectors are very stable over time and radiation dosing. This translates into longer calibration and service intervals, lowering the total cost of ownership.

MECHANICAL CHARACTERISTICS

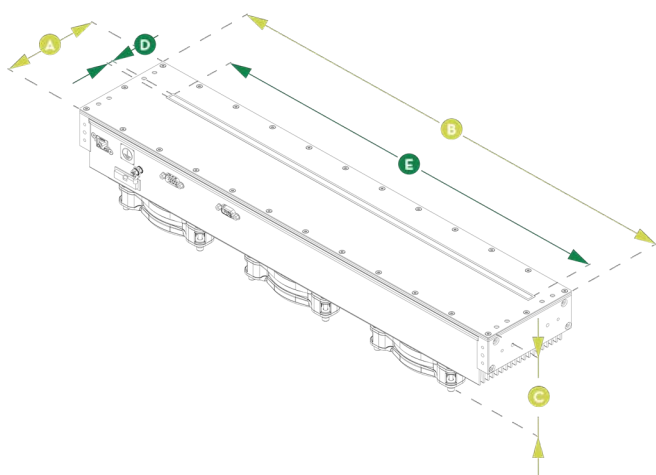

PHYSICAL DIMENSIONS

Active Area Length (E)	103, 154, 205, 308, 360, 411, 514, 668, 822 mm
Active Area Width (D)	6 mm
Length (B)	277 – 1098 mm ¹
Width (A)	120 mm
Thickness (C)	.99 mm ²
Weight	.3 – 17 kg ¹

¹ Depending on the model

² Including the cooling fans, but not the free space required for air-flow.

Unless otherwise specified, Varex Imaging Flat Panel X-ray Detectors are components intended to be integrated into products by X-ray system manufacturers. System manufacturers are responsible for qualifying and validating their products for their intended uses and meeting all applicable regulatory requirements.

Contents in this document are subject to change without notice.

Varex Imaging Corporation

USA

HEADQUARTERS
Salt Lake City, UT
P: +1-801-972-5000

Germany
Walluf
P: +49-6123-971-300

China
Wuxi
P: +86 510 8820-1652

Finland
Espoo
P: +49-6123-971-300

Sweden
Danderyd
P: +49-6123-971-300

©2026 Varex Imaging Corporation. All Rights reserved. Production of any of the material contained herein in any format or media without the express written permission of Varex Imaging Corporation is prohibited. Contents in this document are subject to change without notice. For a complete listing of our global offices, visit www.vareximaging.com

DUAL ENERGY IMAGING

Each incoming photon in every pixel is separately counted in one of the two energy bins producing up to three simultaneous energy-domain images (low, high and total energy). These images can be used for material discrimination, scatter reduction or energy domain artificial intelligence.

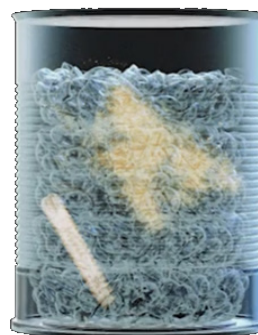

SPECIFICATION HIGHLIGHTS

SENSOR

Scanning Width	102 to 822 mm ¹
Technology	Photon Counting Dual Energy
Energy Ranges	.40 – 300 kVp ¹
Converter	Cadmium Telluride (CdTe)
Pixel Size	100 μm (100% fill-factor)
Pixel Depth	up to 18 bits/pixel
Temperature Control	Active

OPERATION

Mode	Digital TDS Scanning Frame Output
Binning	1x2, 2x2, 4x4

PERFORMANCE

Maximum Speed @ 100 μm:	
Single Energy	54 – 120 m/min ¹
Dual Energy	27 – 60 m/min ¹
Lag	0% (after 6 μGy)

COMMUNICATION

Data Interface	Gigabit Ethernet (RJ45)
SDK Support	Windows