

# 1512 CMOS

## Flat Panel Detector

Making the Invisible Visible



High Resolution with Fast Frame Rates

### OVERVIEW

Varex Imaging's 1512 CMOS Flat Panel X-ray Detector (FPD) is a high speed, low noise X-ray detector with excellent sensitivity. It employs state-of-the-art large-area CMOS (Complementary Metal-Oxide Semiconductor) image sensor technology and is supplied with a range of scintillator and interface options.

Varex Imaging 1512 Flat Panel X-ray Detector has switchable pixel gain that makes it well suited to real-time imaging and CT as well as static imaging with high dynamic range.

### FEATURES AND BENEFITS

- 74.8  $\mu\text{m}$  pixel pitch
- 1944 x 1536 pixel matrix
- High Sensitivity and High Dynamic Range modes
- Operation up to 225 kV
- Suitable for real-time imaging at up to 86 fps
- 1 x 1, 2 x 2 and 4 x 4 pixel binning options
- High DQE
- Various scintillator options available
- Input/output for X-ray generator synchronization
- Camera Link or GigE Vision data connection

### APPLICATIONS<sup>1</sup>

- Medical
- Dental
- Veterinary
- Life sciences

## TECHNICAL SPECIFICATIONS

### SENSOR

Pixel Size (µm)	74.8
Sensitive Area (mm <sup>2</sup> )	145.4 × 114.9
Pixel Matrix (px)	1944 × 1536

### MAX FRAME RATE (FPS)

Pixel Binning	Camera Link	GigE Vision
1×1	26	14
2×2	70	56
4×4	86	86

### IMAGE PERFORMANCE

Dynamic Range (dB)	
High Dynamic Range Mode	typ. 71
High Sensitivity Mode	typ. 68
X-ray Energy Range (kV)	12 - 130

### MECHANICAL

Weight (kg)	2.2
Dimensions l × w × h (mm <sup>3</sup> )	223.5 × 150 × 42

### COMMUNICATIONS

Camera Link	Base 80 Mhz (1 cable)
GigE Vision	1000BASE-T
Digital Output	14-bit
Control Channel	115 kBaud serial link / Camera Link / GigE Vision
Sync Ports	BNC
Sync In Port	3 - 15 V edge or level trigger
Sync Out Port	TTL (0 - 5.0 V)
Software	Support for 32 and 64 bit Windows® OS

### POWER

	Camera Link	GigE Vision
Dissipation	8.5 W	10.5 W

### SCINTILLATOR OPTIONS

High Efficiency microcolumnar CsI

High Resolution microcolumnar CsI

Various Gd<sub>2</sub>O<sub>2</sub>S:Tb (GOS) fluorescent screens

### TEMPERATURE RANGE

Operating Temperature	+10°C to +40°C
Storage Temperature	-10°C to +50°C

### MECHANICAL CHARACTERISTICS

(Dimensions in mm)

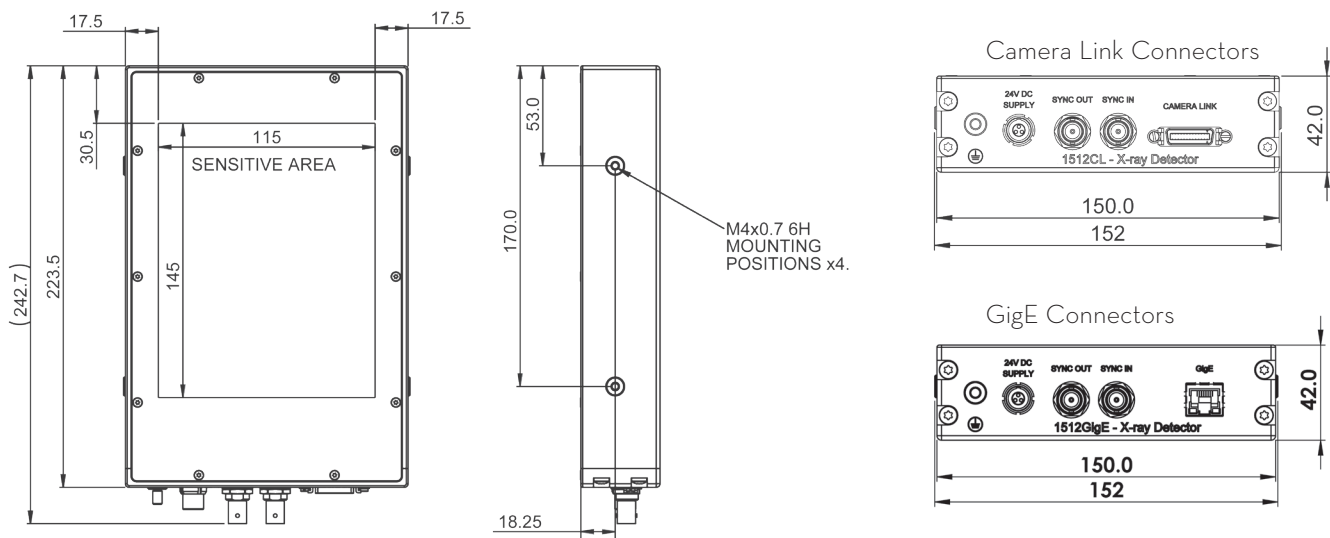

<sup>1</sup> Unless otherwise specified, Varex Imaging Flat Panel X-ray Detectors are components intended to be integrated into products by X-ray system manufacturers. System manufacturers are responsible for qualifying and validating their products for their intended uses and meeting all applicable regulatory requirements.

Contents in this document are subject to change without notice.



**VAREX**  
IMAGING

USA HEADQUARTERS  
Salt Lake City, UT  
P: +1-801-972-5000

GERMANY  
Walluf  
P: +49-6123-971-300

CHINA  
Wuxi  
P: +86 510 8592-9201

For a complete listing of our global offices,  
visit [www.vareximaging.com](http://www.vareximaging.com)

©2022 Varex Imaging Corporation. All Rights reserved. Production of any of the material contained herein in any format or media without the express written permission of Varex Imaging Corporation is prohibited.